

BROMBAL

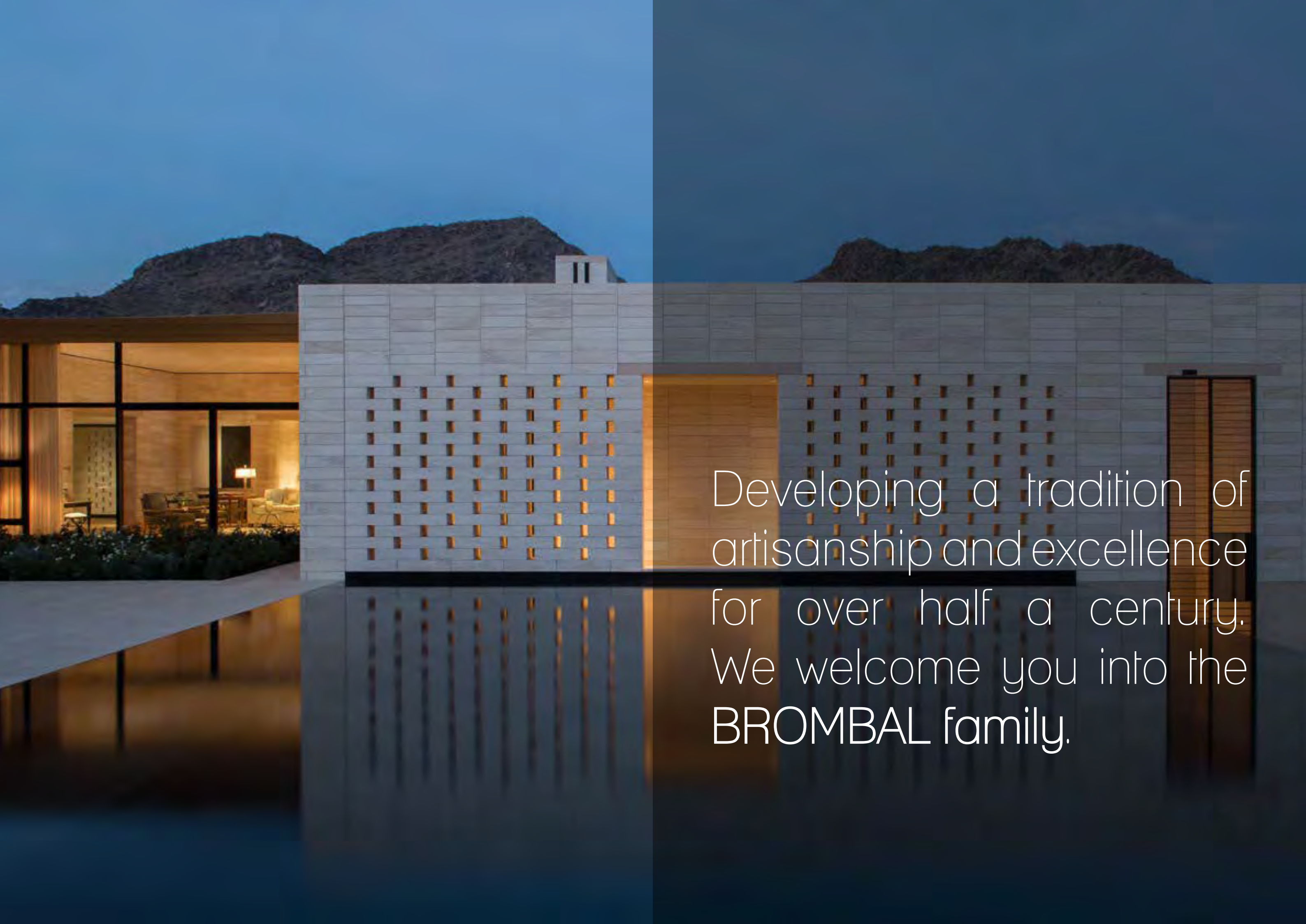

THE  
WORLD'S  
FIRST  
LUXURY  
THERMALLY  
BROKEN  
METAL  
WINDOWS  
& DOORS

A photograph of a modern building at dusk. The building features a prominent facade of light-colored, perforated panels that create a grid of small, glowing rectangular openings. To the left, a large glass-walled interior is visible, showing a well-lit living area with furniture. The building is reflected in a body of water in the foreground. In the background, dark, rugged mountains are silhouetted against a deep blue twilight sky. The overall mood is serene and sophisticated.

Developing a tradition of  
artisanship and excellence  
for over half a century.  
We welcome you into the  
**BROMBAL** family.



# INDEX

<b>FIVE KEY ATTRIBUTES</b>	
HISTORY	8
PARTNERS	14
QUALITY & PERFORMANCE	18
Thermally Broken - Cold Rolled System	20
Structural Reinforcement Design	22
Mullion Options	24
Accessory Fabrication	28
Wind Load and Design Pressure Calculations - Performance and Code Compliance	29
Brombal Lab	30
Certifications	31
Gasketing - Multi-Point Lock	32
Hinges	33
<b>FREEDOM TO CREATE</b>	
4 Base Metals	36
Extensive Product Portfolio	44
Hardware	46
Burnishing Plant	48
Mechanical Engineering for Operable Glass Wall	50
Thousands of Finishes	52
Custom Doors	53
Screens	54
Customization	58
Lift and Slide Sill Options	72
Door Sill Options	74
<b>SERVICES</b>	
Feasibility Studies	78
Installation and Field Services	79
Shop Drawings	80
Samples and Mock-Ups	81
<b>SYSTEMS</b>	
OS2 Series	85
OS2 65	86
OS2 77	94
OS2 Wood Option	102
OS2 65-77 Luxury-Essentials Line	104
EBE Series	106
EBE 65	108
EBE 73	114
EBE 85	120
EBE Style	126
EBE Metal Wood	128
CURTAIN WALL Series	130
CURTAIN WALL 4F1	132
CURTAIN WALL 4F2	134
<b>PORTFOLIO</b>	
	136

# 3 CENTURIES OF COMBINED EXPERIENCE

Studying and perfecting the art and craftsmanship of metalworking. There is no substitution for experience!  
"Developing a tradition of artisanship and excellence for over half a century, we are honored to welcome you to the BROMBAL family!"

BROMBAL is a leader in the production of Italian manufactured door, window and facade systems in galvanized steel, corten steel, stainless steel and brass. Each year, almost 7 million linear feet of profile bars are used to produce 200,000 doors and windows. BROMBAL boasts years of experience and constant, dedicated commitment to achieve the highest standards of quality and innovation for their products.

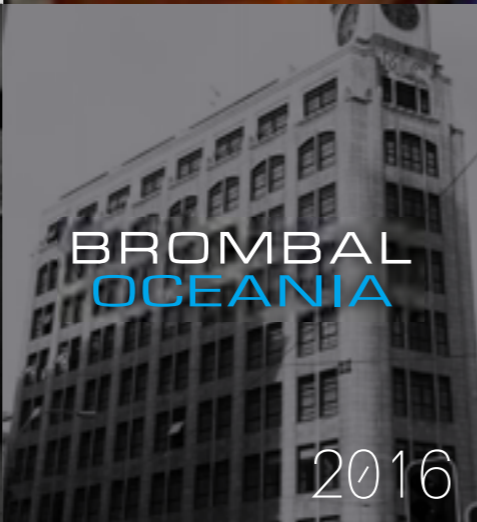

- 1959 Pietro Brombal began his apprenticeship at age 14 as a metal craftsman
- 1970 Pietro Brombal established a metal fabrication shop in Altivole, Italy, specializing in custom window and door frames.
- 1975 Pietro Brombal opened his own workshop in Altivole, Italy, proudly named "Serramenti Brombal."
- 1979 Two sons Leonardo and Pierpaolo are taught the steel business by their father at an early age.
- 1995 Pietro Brombal invests into Secco Sistemi Spa and becomes partner and member of their Board of Directors.
- 2002 Today Leonardo oversees manufacturing and Pierpaolo manages sales and marketing. Including their father, they have over 100 years of steel/bronze fenestration experience.
- 2004 Brombal's first thermally broken project sold into the US market in Napa Valley, CA.
- 2005 Brombal completed the largest project to date, the Five Star Molino Stucky Hilton resort hotel in Venice, Italy. Over 2000 window units were used in the restoration project.
- 2007 Brombal expanded operations into a new state of the art facility in Altivole, Italy.
- 2011 Brombal USA founded with partners Domenick Siano and William Polinsky to provide excellent customer service and commitment to the US market.
- 2016 Brombal Oceania founded with Gherardo Gambaro & Jon Begg to provide & service the needs of Australia & New Zealand.
- 2017 Dave Behan becomes additional partner and CEO of Brombal USA.

Brombal is the global leader in the thermally-broken luxury steel and bronze fenestration industry. They continue their rich family tradition of metal crafting artisanship by partnering with the world's most talented architects and builders. Seamless integration of an elegant product into sophisticated designs. This is what sets Brombal apart.

BROMBAL  
USA

BROMBAL  
OCEANIA

## HISTORY

---

- Proven Fabrication Methods
- Experience
- Old World Craftsmanship  
Meets New World Technology

---

For over half a century, our production methods are founded on the highest quality of work and artisanal craftsmanship, which pair together with the drive for innovation and allow us to stay at the forefront of an ever changing market.

Production methods are developed and optimized specifically for each metal, a guideline for the passion and the love of our work.

A lifetime of experience that combines artisanship and innovation; tradition and modernity; architecture and design.



There are few words which are able to express the value of experience offered to you by the Brombal Family.

IN UNION  
THERE IS GREAT  
STRENGTH



Attaining greatness is possible when you join with others who have the same vision and business practices that lead to greatness. This is why Brombal takes great care in selecting our partners. Working with industry leaders like Secco Sistemi, Zanatta Vetro, and Meccatronica allows Brombal to offer their clients a finished product that personifies excellence, ingenuity, and design.





## Secco Sistemi

Secco Sistemi – manufacturer and engineers of cold rolled and thermally-broken profiles/systems, Brombal is their top client



## Meccatronica Automations

Meccatronica – manufacturer of complex motors for automated operation of door, window, and gizmo systems



Partners

## Zanatta Vetro

Zanatta Vetro – manufacturer of insulated glass units; size capacity = 10'-6" x 24'-0" (252 sq/ft), 10-year warranty, extremely clear high performance glass, low profile and square corner spacer bars



QUALITY & PERFORMANCE

PROVIDING EXTENSIVE  
EXPERIENCE AND  
THE PROFOUND  
KNOWLEDGE OF METAL  
CHARACTERISTICS

The largest investment Brombal makes each year is in the testing and performance evaluation of our products. Why? Because we know this is what our customers expect. You are trusting in us to provide products that protect your investment, that shield you from the fiercest elements, that perform year-after-year without fail. There are no substitutes when your comfort and peace of mind are on the line.

## QUALITY & PERFORMANCE

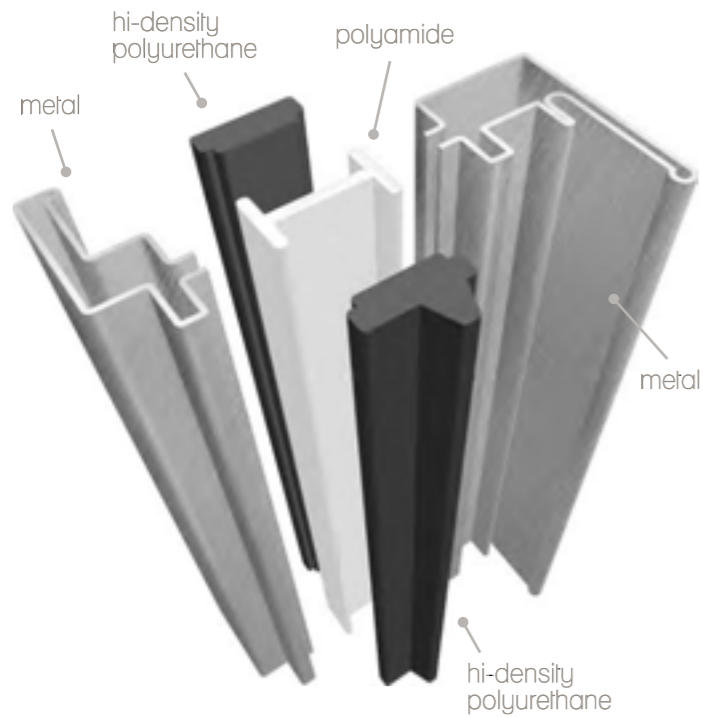

### Thermally Broken Cold Rolled System

The use of metal profiles to create doors and windows began in the mid-1940's with metal rolling technology. The process combined a series of rollers that generate tubular profiles which require crimping and welding. In 1990 the first Thermally Broken window was developed. It was a combination the rolled metal shapes, a polyamide which holds the sections together, and a high density resin which permanently bonds the sections together creating a durable long lasting profile. This 2-piece system provides industry leading torsional and shear strength allowing Brombal to produce larger sizes with minimal sightlines while guaranteeing structural performance. With the ability to combine industrial tradition and technological innovation, there are now over 200 different profiles available in four different materials and multiple finishes. With a dedication to technological development Brombal has become the leader in the metal fenestration industry.



NEVER  
COMPROMISING  
QUALITY OR  
PERFORMANCE

# QUALITY & PERFORMANCE

## Structural Reinforcement Design

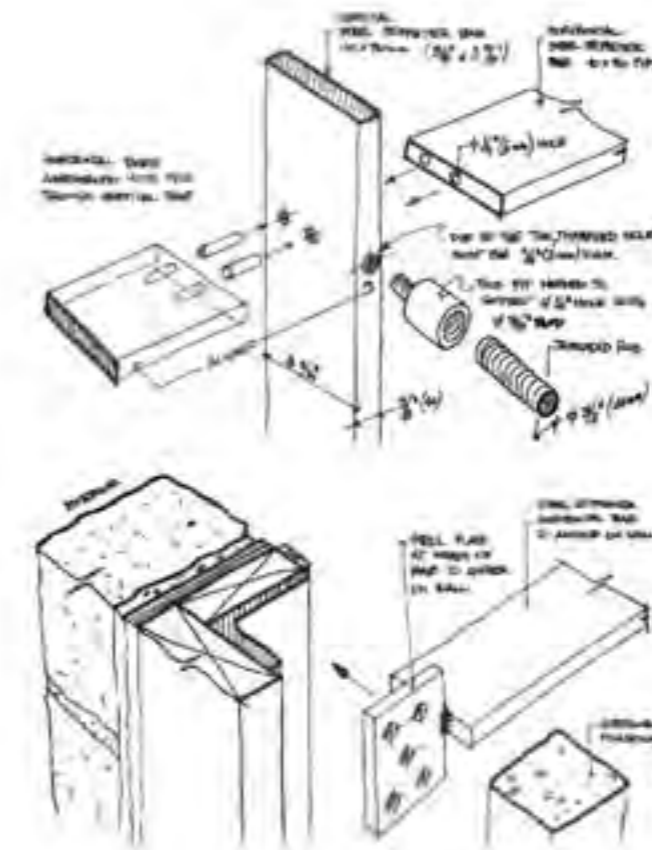

## STRUCTURAL REINFORCEMENT DESIGN

As walls of glass get more extensive the need for engineered structural reinforcements becomes a necessity. Brombal not only designs stiffeners but we manufacture them with the same thermally-broken integrity found throughout our window and door systems.

# QUALITY & PERFORMANCE

Mullion options

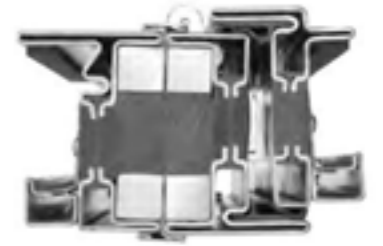
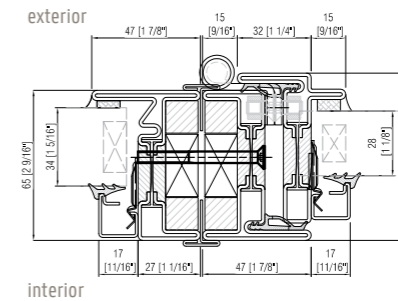

OS2 FXD mullered to OS2 CSMT with structural support inside the profile

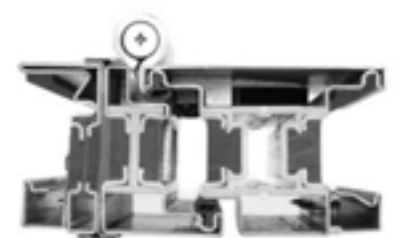
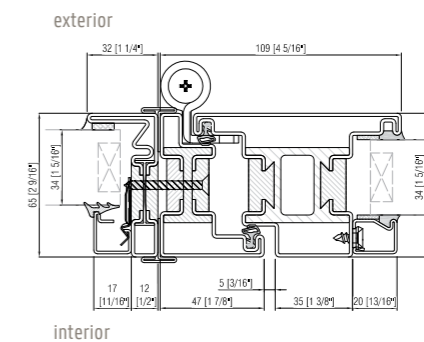

OS2 FXD mullered to EBE Hinged Door

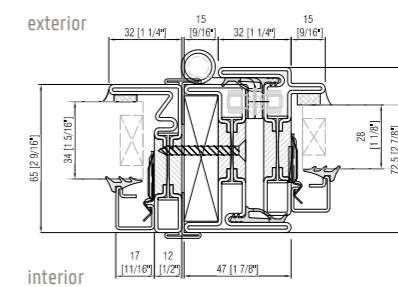

OS2 FXD mullered to OS2 CSMT Outswing

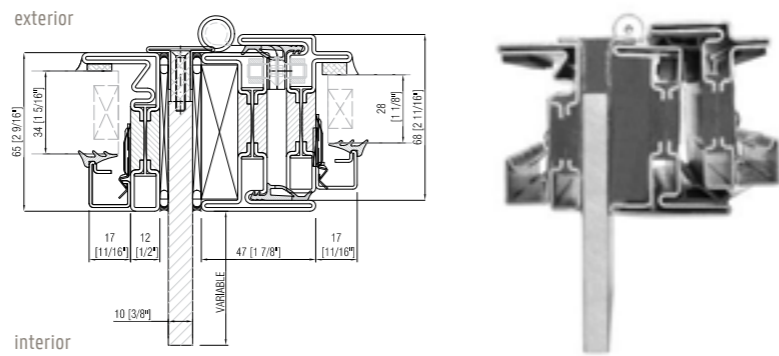

OS2 FXD muller to OS2 CSMT with structural 3/8" stiffener

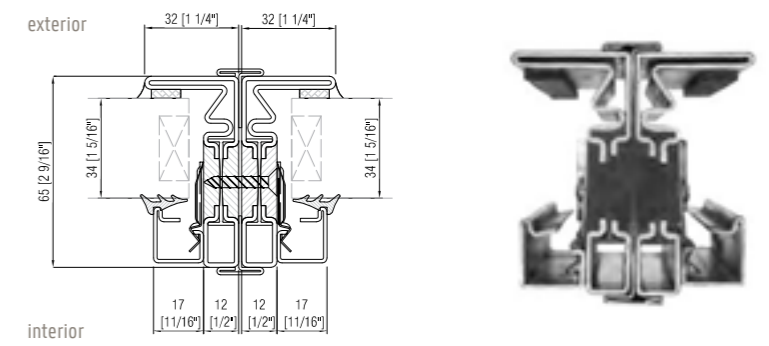

OS2 FXD direct muller to OS2 FXD

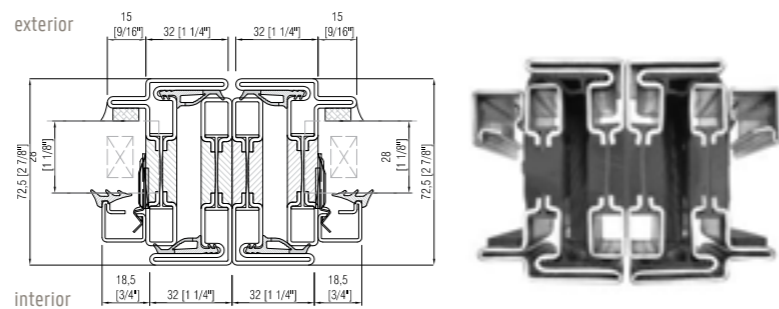

OS2 CSMT direct muller to OS2 CSMT

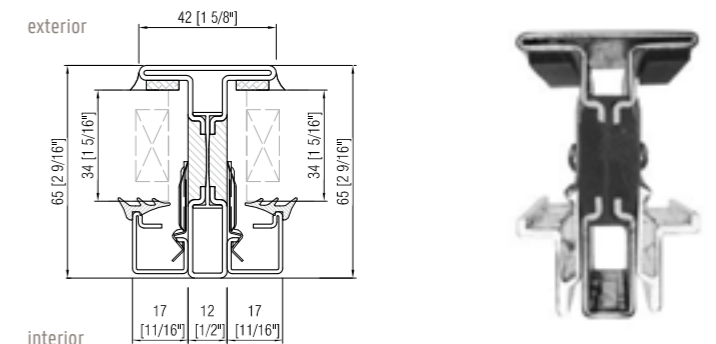

SOLUTION 1 - OS2 muntin

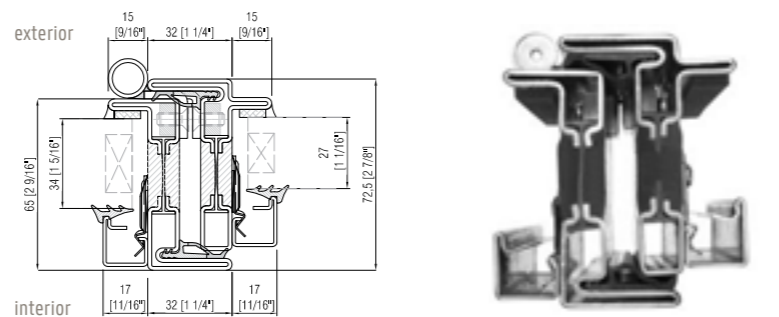

OS2 common frame FXD and CSMT

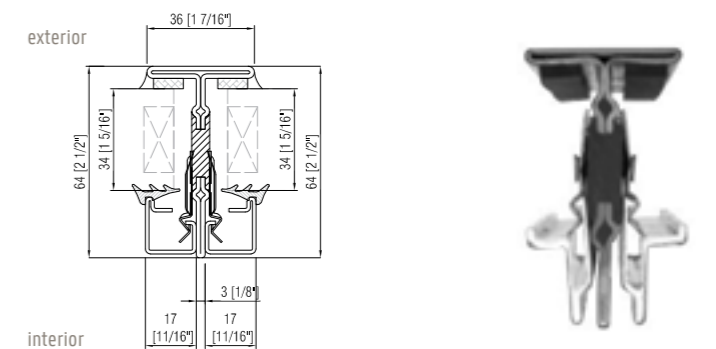

SOLUTION 2 - OS2 narrow muntin

# QUALITY & PERFORMANCE

## Accessory Fabrication

It's one thing for a company to say "our product is perfect." The right thing to say is "our product fits perfectly." Brombal prides ourselves in seamlessly integrating our luxury fenestration into the building envelope. We want the purpose of every component to be harmonious with its surroundings. This defines perfection.



## Wind Load and Design Pressure Calculations, Performance and Code Compliance

Beauty is only skin deep as the saying goes. Brombal realizes the true measures of sustainable quality life in our product's performance. Thanks to our team of engineers and designers we develop our products to meet your project specifications to ensure security for home and family.



no pressure

at 100 psf



Quality & Performance



# QUALITY & PERFORMANCE

## Brombal Lab

Going above and beyond to ensure the highest level of quality performance, the Brombal Lab is equipped with the most updated testing machines which are certified by American Institutes. This allows us to test each unit for maximum performance in areas of air, water, structural, and hurricane forced winds. An unparalleled 360 degree service to our clients. When the stakes are this high you can't settle for 2nd best.

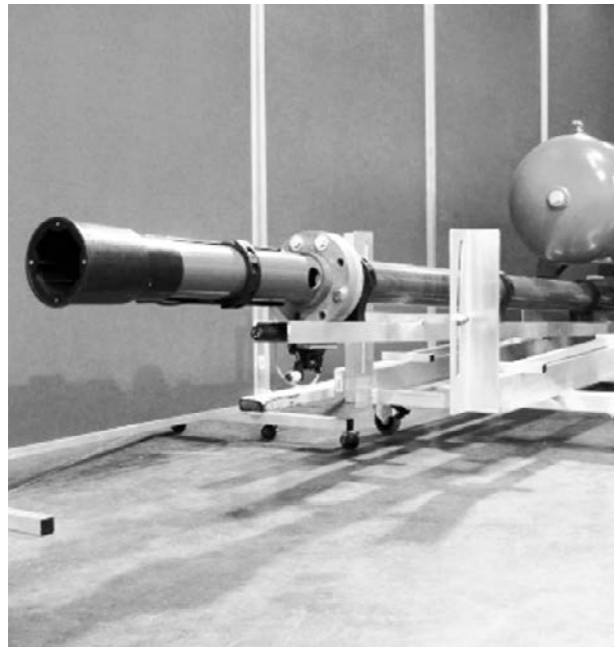

Quality & Performance

## Certifications

Whether Mother Nature blows fierce winds, unleashes cascading rains, exposes bright rays of sun, or sends flurries of snow and cold you have the assurance that Brombal has designed systems that pass the most stringent certification requirements in the world. In fact Brombal offers the only luxury thermally-broken steel or bronze systems to pass the world's toughest fenestration standards - Miami Dade and Florida Impact Ratings. This speaks volumes about our dedicated strategy to provide our clients with a product that not only looks beautiful but performs beautifully.





## QUALITY & PERFORMANCE

---

### Multi-Point Lock

---

Multi-point hardware is essential in providing security and weather tight performance. This is why Brombal offers it as a standard on all of our window and door units. Brombal uses a unique mortising fabrication process so the hardware fits into the profile like a glove.

### Gasket

---

Air and water tightness are essential for providing comfort inside your home. Brombal uses friction fit, heavy gauge, EPDM weather-stripping that will protect you against the damaging effects of Mother Nature.



Quality & Performance

### Hinges

---

Hinges bear the massive weights of heavy sash and door panels. This is why Brombal chooses to use heavy-duty adjustable hinges available in galvanized, corten or stainless steel that will guarantee a lifetime of responsive operation for your doors and windows.



FREEDOM TO CREATE

# OPEN YOUR MIND

Free to sit back and think, without any constraint, obligation or restriction. Brombal offers this, there is no limit that is given, only the imagination. Our experience, professionalism and technique, will allow you to realize your dreams.

## FREEDOM TO CREATE

---

4 BASE METALS - Corten Steel

A unique material embraced by artists and architects alike for its aesthetic value and exclusiveness.

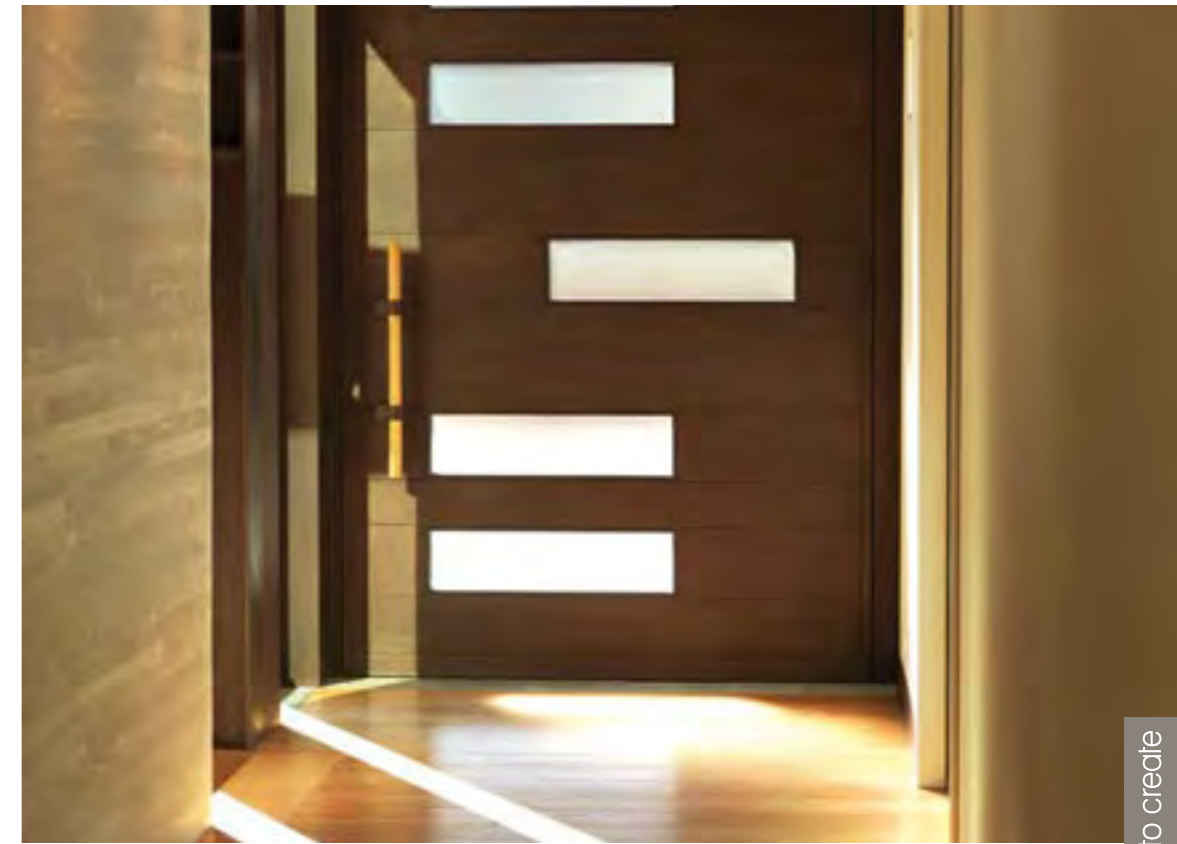

## CORTEN STEEL

Corten steel is a high-resistance alloy containing copper, chrome and phosphorous. It became popular in the mid 1930's used mainly for heavy construction and sculptures. It is a material that is characterized by being highly resistant to corrosion with high tensile strength. These alloys are self-protective through the formation of a superficial coating that prevents the progressive extending of the corrosion process. The oxidation process can be accelerated through a process done in house where oxidizing is done by hand over a

2-3 week period. The resulting finish is a material with unique coloring of warm shades of brown and orange. Thanks to Brombal's innovative and technological advancements, we were the first manufacturer to produce windows and doors from this material which is highly appreciated by the architectural community.

## FREEDOM TO CREATE

4 BASE METALS -Stainless Steel

Guaranteeing durability even in the harshest environments.



## STAINLESS STEEL

The advent of stainless steel dates back to the beginning of the 20th century. This alloy is made with iron, chrome, nickel and molybdenum which protects its surface from corrosion. Throughout the years, stainless steel has undergone many technical improvements and has thus become universally famous for its high durability in a variety of environments. The advances during the last decades have enabled a wide range of products to designers that meet their needs for using this material in aggressive environments. For the production of our profiles, we use AISI 304 and AISI 316L stainless steel. AISI 304, most commonly used in a satin or polished finish, is typically used in

less aggressive environments while AISI 316L, most commonly provided in scotch-brite or a polished finish, is mainly used in marine environments and is the most durable stainless steel available. The physical features of these alloys allow for narrow sections with lower visual impact. Stainless steel guarantees a long life cycle with minimal maintenance. With its reduced thermal conductivity, stainless steel is suitable for use in the most challenging conditions.

## FREEDOM TO CREATE

### 4 BASE METALS - Brass

Excellent resistance to corrosion while offering the highly aesthetic value of bronze for prestigious architectural solutions.



## BRASS

This copper-zinc alloy discovered in the 1st century, can be dated back in its current version to the 16th century. Brass is well known for its ability to naturally oxidize when in contact with air while its physical features remain unchanged. This oxidation allows brass to obtain a particular antique bronze finish, ideal for prestigious refurbishment of historic buildings as well as offering an elegant yet traditional look for new construction. Our frames are made with an OT67 alloy. This alloy offers a high percentage of copper (67%) for a high resistance to corrosion while the zinc (33%) improves its mechanical properties such as hardness and tensile strength. Brombal has developed a burnishing process for this alloy that accelerates the natural oxidation process. This process creates a variety

of beautiful bronze-like patinas while increasing its resistance to corrosion. With this process, the alloy requires less maintenance and displays a variety of warm and elegant shades of coloring that bring to mind the old bronze metal that is unique and elegant. This self-protecting patina also makes the final product ideal for aggressive environments like a marine setting or corrosive environment.

## FREEDOM TO CREATE

4 BASE METALS - Galvanized Steel

Joining the strength of steel with an infinite range of colors and finishes provides endless solutions for every project.



## GALVANIZED STEEL

The use of steel windows and doors dates back to the late 1840's, but since the Industrial Revolution in the second half of the 19th Century, there has been a significant increase in development of the products. The Bauhaus movement established steel as an indispensable architectural component in the 1920s and 1930s, giving it authority and stature. The 1950s saw the development of cold rolling and the evolution of the simple L,T and Z shaped profiles, expanding the product range with more complex shapes that could meet the ever growing market demand for innovative systems. This was especially true for doors and windows with a thermal break. Our frame uses a specific steel alloy,

the FeP02 with a GZ200n hot zinc coating (equivalent to 200 gr/sqm per side), that protects the profile from oxidation both on the interior and the exterior surface. The subsequent finishing process, call skin-passing, allows for a better paint adhesion thanks to polyester powders which is available in a wide range of colors and custom finishes. The structural integrity of the steel allows for profiles with narrow sightlines and unsurpassed structural integrity.

# FREEDOM TO CREATE

Extensive Product Portfolio



Freedom to create

## EXTENSIVE PRODUCT PORTFOLIO

Simplistic but elegant design infused in every type of opening, we guarantee your satisfaction.

Where others leave off Brombal is just beginning. We offer the most extensive product portfolio in the industry and it continuously expands as we bring to reality the desires of our customers.

With simplicity, talent and experience we provide expertly engineered products to fill any opening in the building envelope. We love accepting a challenge. It allows architects creative license in turn providing reality to Homeowners' dreams.

FREEDOM TO CREATE

Hardware



## SPECIAL HARDWARE

Hardware is an expression of form and function. It must be comfortable and familiar while offering beautiful elegance. It is the customer's connection to our craftsmanship. It must be in perfect harmony. Open your eyes to the possibilities of true luxury.



FREEDOM TO CREATE

Burnishing Plant



## BURNISHING PLANT

At Brombal no details are left to chance. Burnishing metal to a specific patina requires a craftsman's touch. This is why we have invested in a new state-of-the-art burnishing plant. Our burnishing plant guarantees us the flexibility to offer unique living finishes that enhance the metal's natural beauty.

# FREEDOM TO CREATE

Mechanical Engineering  
for Operable Glass Wall



Project Name - Chicken Point Cabin  
Photographer - Undine Prohl, courtesy Olson Kundig

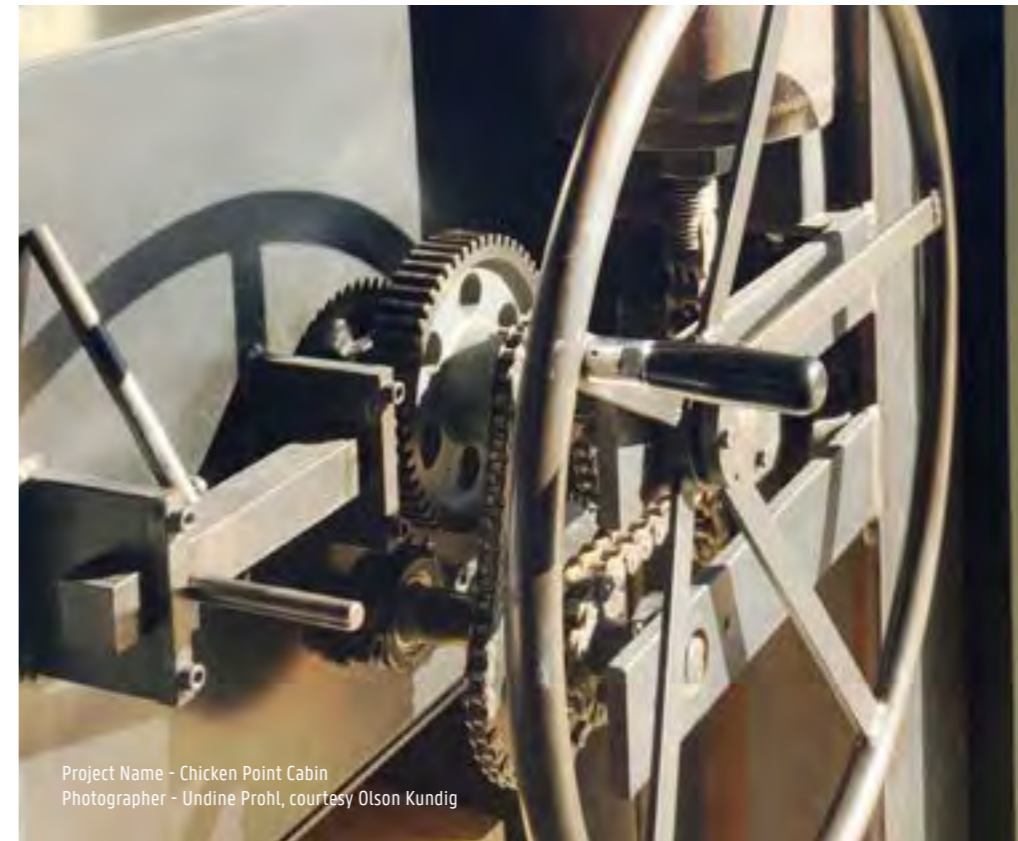

Project Name - Chicken Point Cabin  
Photographer - Undine Prohl, courtesy Olson Kundig

## MECHANICAL ENGINEERING FOR OPERABLE GLASS WALL

Imagination should be cultivated...this is why Brombal fully embraces the development of entire walls of operating glass. These units are jewels in the crown of mechanism. A complete thermally-broken glazing wall which is water and air resistant, operated by automation or mechanism means - pivoting, folding, swinging, guillotine, or...let your imagination run wild.

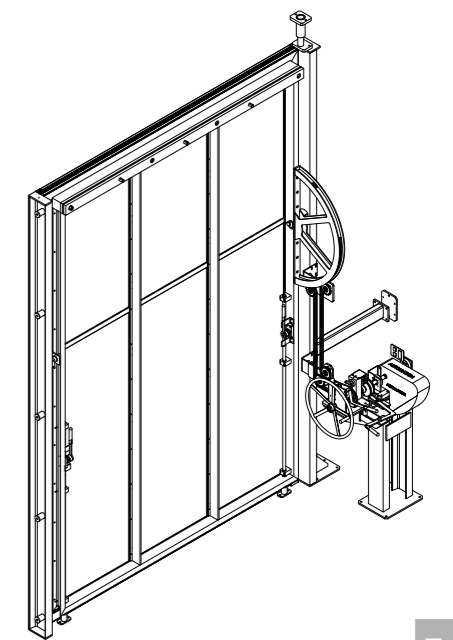

Designed in collaboration with Olson Kundig. These impressive operating walls of glass meet the most challenging glazing requests in the world.



## Thousands of Finishes

---

Michelangelo created masterpieces through the use of vibrant colors which have endured the test of time. At Brombal, we allow the client to choose from a vast array of color palettes that when combined with state of the art application technology we extend the Italian tradition of lasting quality for your fenestration masterpiece!

## FREEDOM TO CREATE

---

### Custom Doors

---

Brombal offers an extensive variety of door options to fit every imaginable opening: Pivot doors, Lift/Slide, Multi-slide, Bi-fold and Standard hinged. Once you touch and feel how smooth they operate you will know you are experiencing something truly unique.



# FREEDOM TO CREATE

## Screens



### Fixed Magnetic

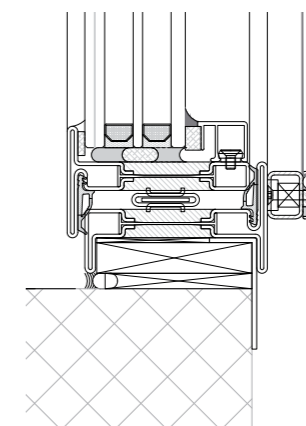

Fixed magnetized screens minimize the screen frame profile and allow for easy removal for convenient storage or cleaning.



### Fixed

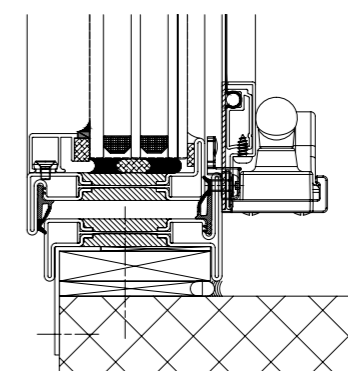

Mechanically fastened fixed screens have covers that meticulously match all materials.

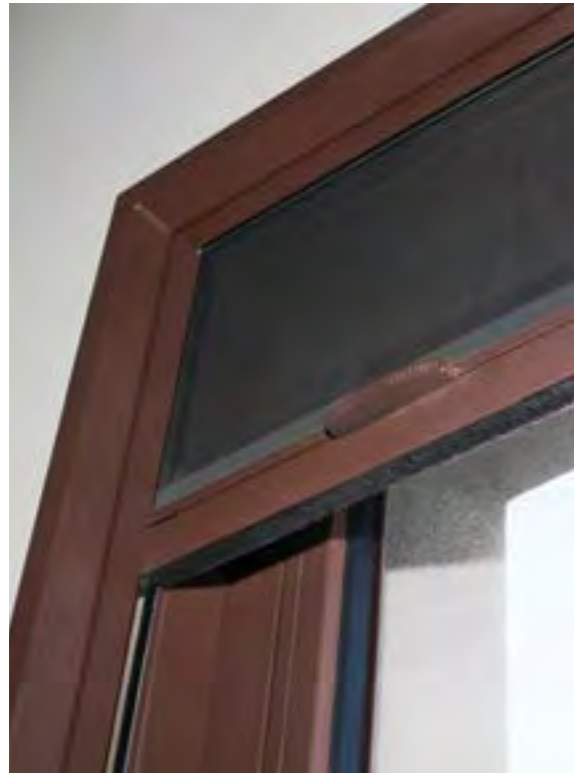

## Roll Down

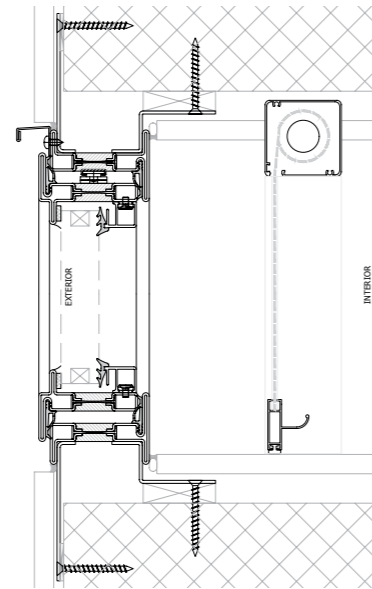

Roll down screens allow for concealment when unwanted, or easy accessibility when required.

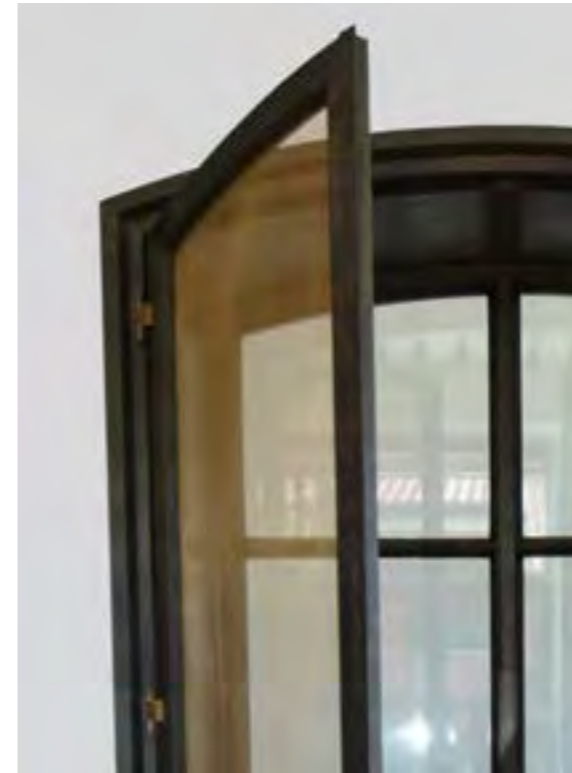

## Hinge

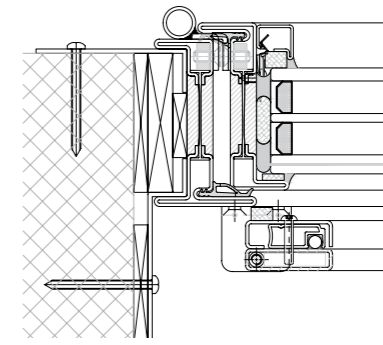

Hinged screens offer a traditionally elegant solution for improved ventilation and easy access to the operable door leaf or window sash.



## Retractable

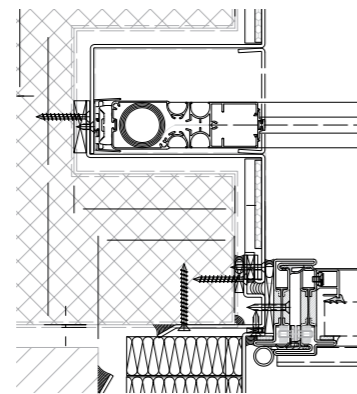

Retractable door screens slide horizontally into concealed canisters providing a convenient and concealed insect barrier.



## Slide

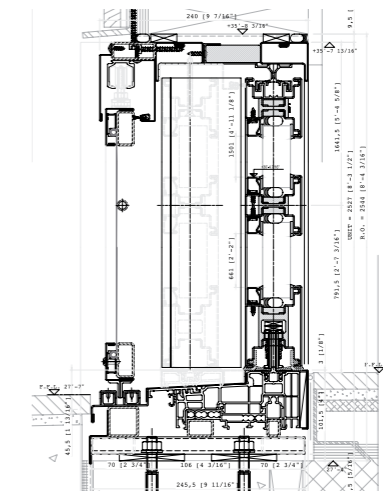

Sliding door screens provide a simplistic approach to screening large door openings.

# FREEDOM TO CREATE

Customization



## CUSTOMIZATION

Customization capabilities are key to Brombal's success and have paved the way to us becoming the world leader in luxury fenestration. Where other companies stop short Brombal is found paving the way in product innovation. Our clients expect us to meet their demanding design intent. Boxes are boring which is why we live without boundaries.

# Customization: Curved Fixed Frames Bent Glass

Bending frames to match perfectly with curved glass is no easy task. There is no room for error. Brombal's precision methods of fabrication and engineering ensure all aspects will come together in perfect unison.

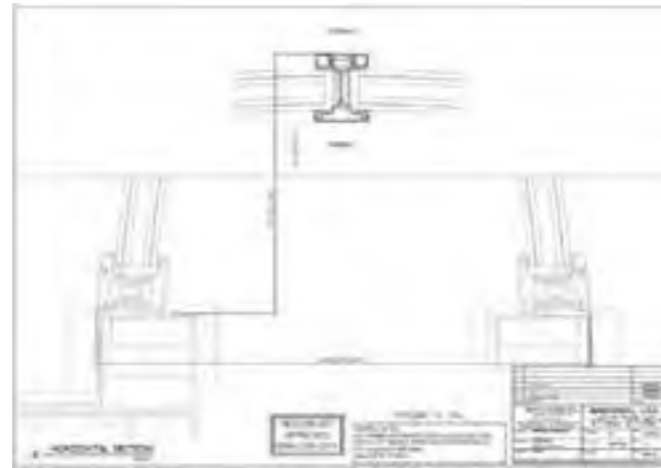
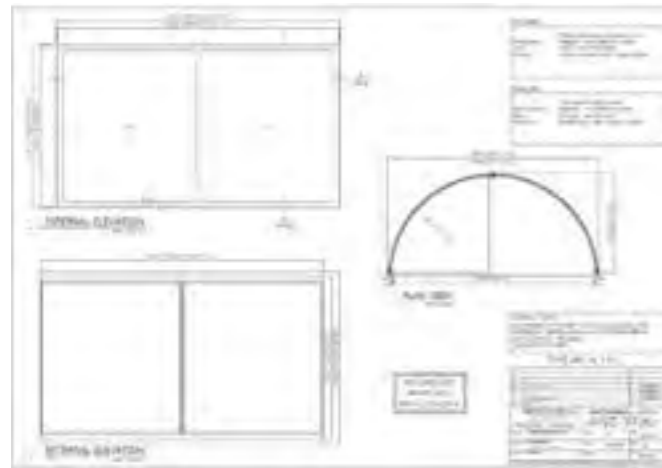
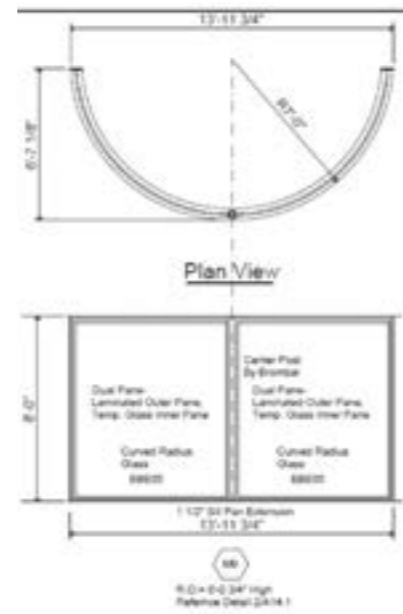

Freedom to create

Customization:  
Flashings and Sill Pans

Brombal wants to create a seamless transition between product and structure. This is why we offer to supply metal flashings, sill pans, and covers. We call this "Solution Based Fabrication."

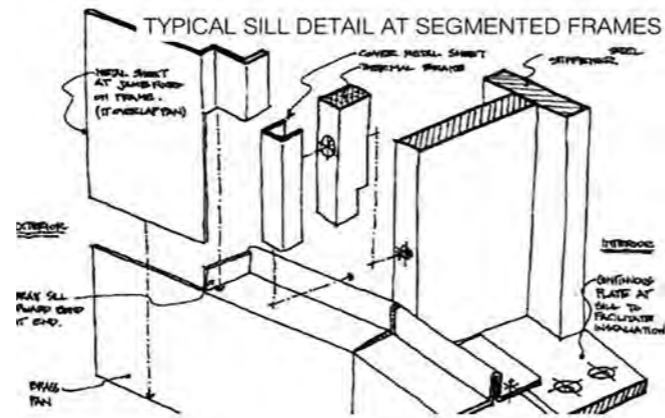
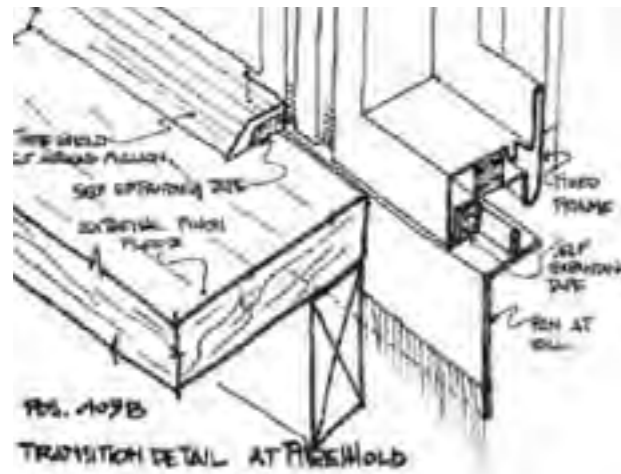
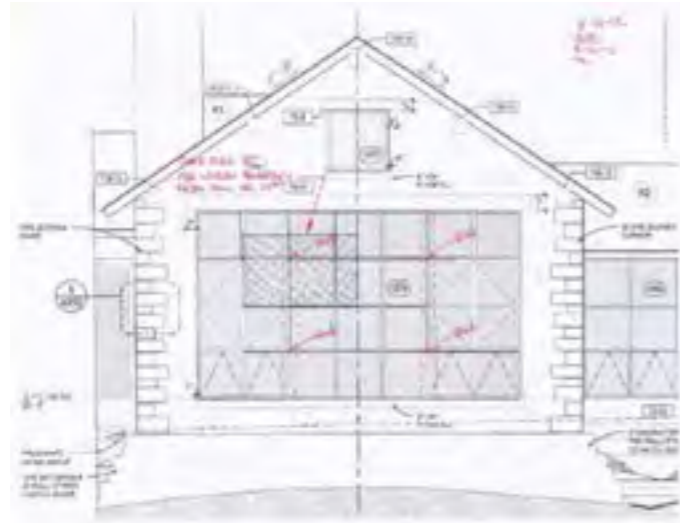

Freedom to create



Customization:  
12' x 11'-3" Single Panel  
Pocket Lift/Slide

Operable 3' wide door built within  
TDL - designed to conceal operable door

For every day use this client wanted to conceal a hinged door for quick and easy entry within this massive pocketing lift/slide door system. During parties the door is slid into the pocket providing an easy transition between indoor and outdoor space.

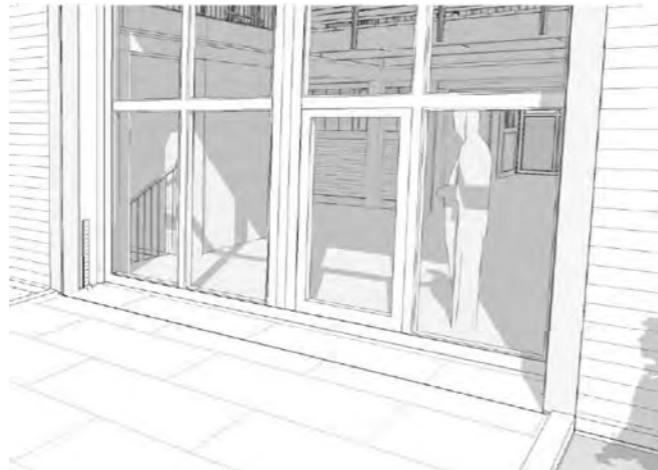
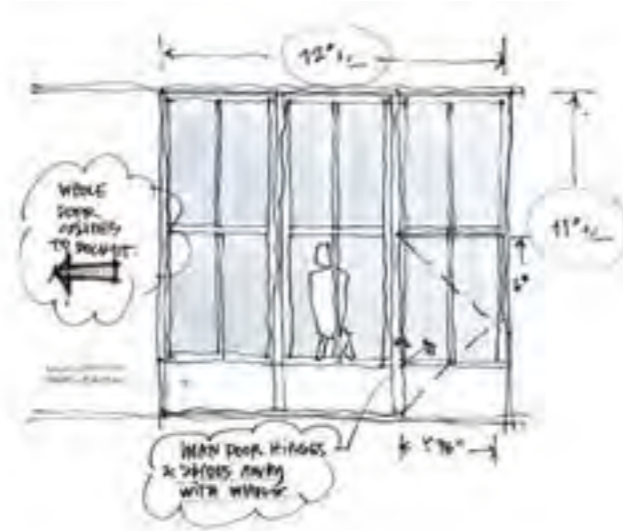

# Customization: Inclined Motorized Sliding Doors

The architect was hoping to combine two systems into one... Skylights and Sliding doors. The automated door openings were built with an inverted angle to allow more natural light to enter the space while providing access to outdoor living spaces.

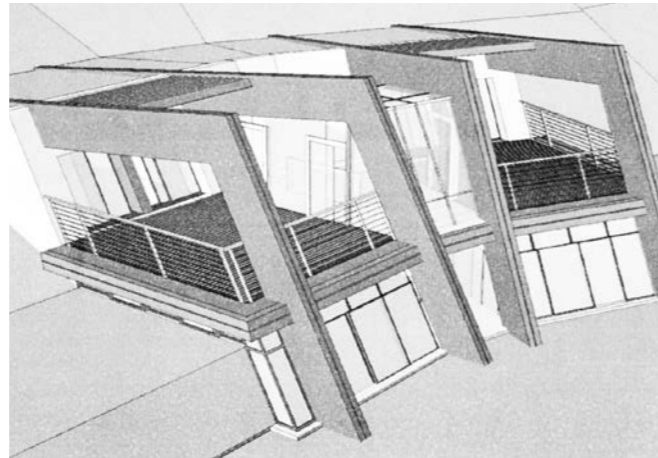
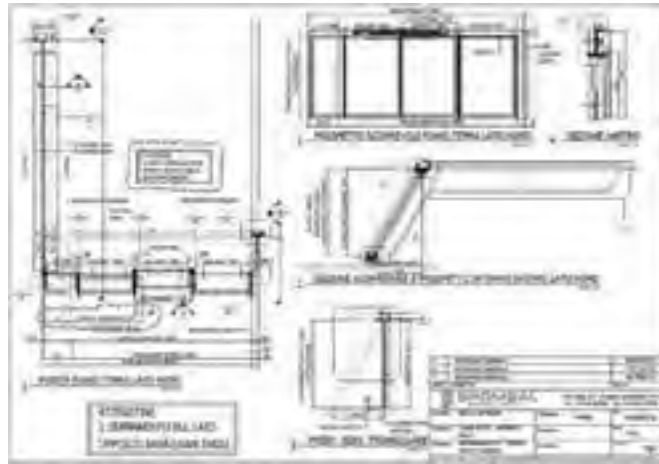
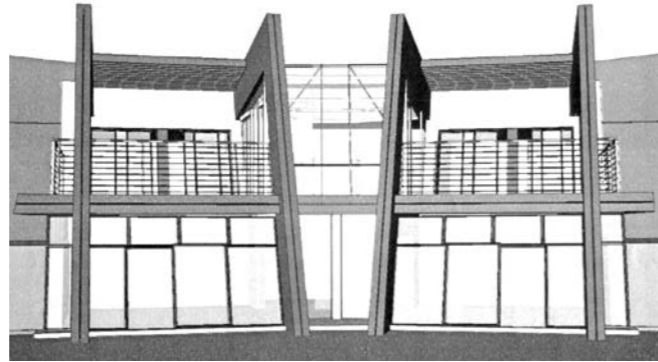

Freedom to create

Customization:  
Curved Bifold Door

Some designs are just too "square" which is why Brombal provided this one of a kind curved bifold door system. As a result the beautiful mountain setting is maximized with unobstructed panoramic views.

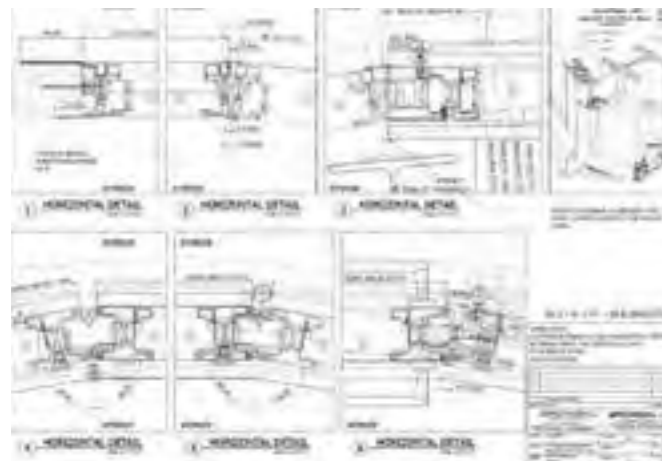
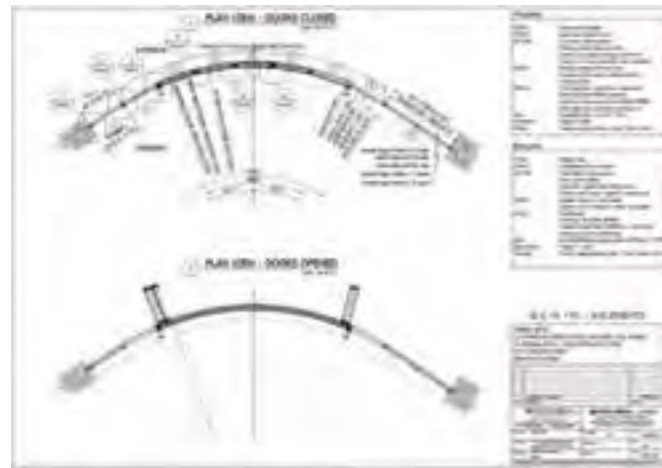
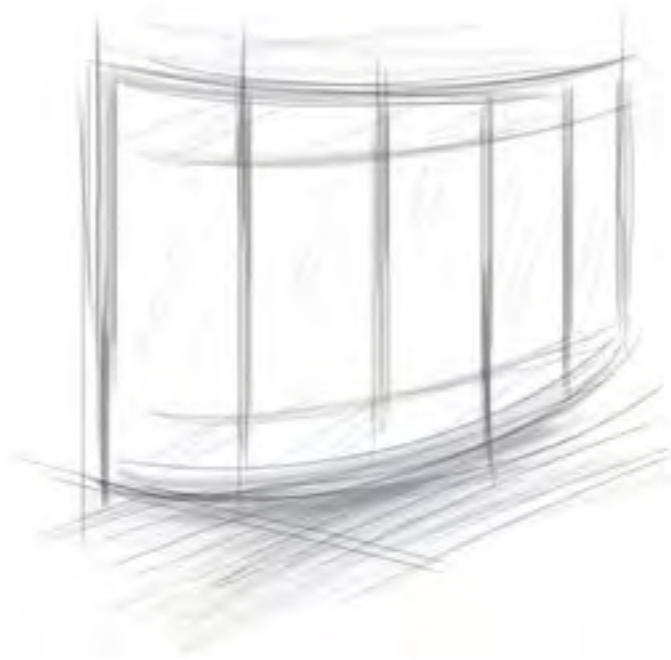

Freedom to create

Customization:  
Skylight

Opening a view to the sky which brings natural light into confined spaces. We will design a variety of shapes and sizes to meet your specific skylight needs. Motorized venting applications are also available.

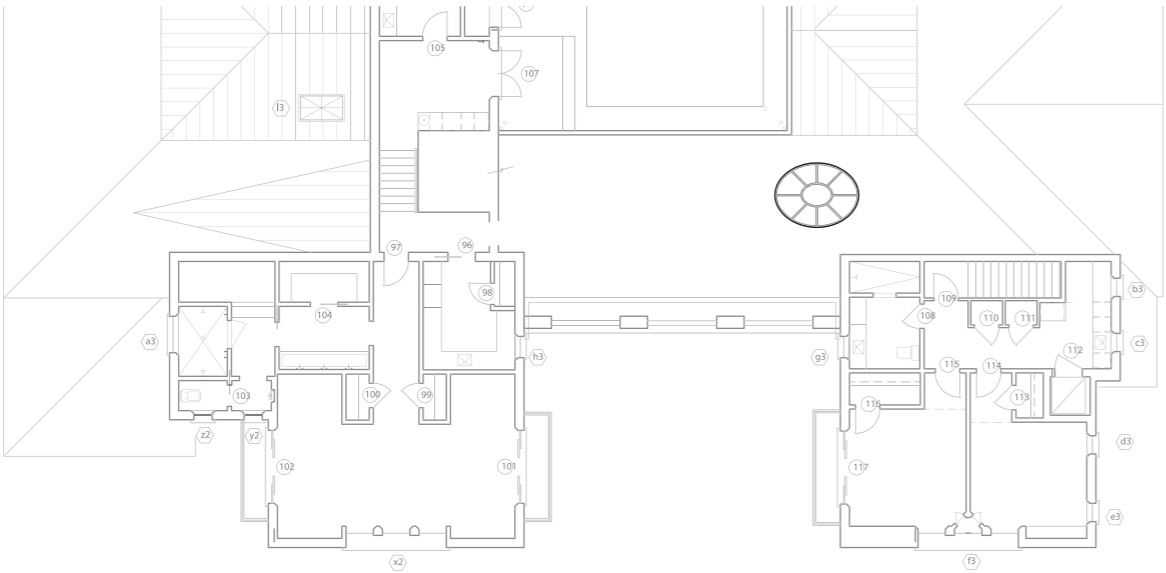
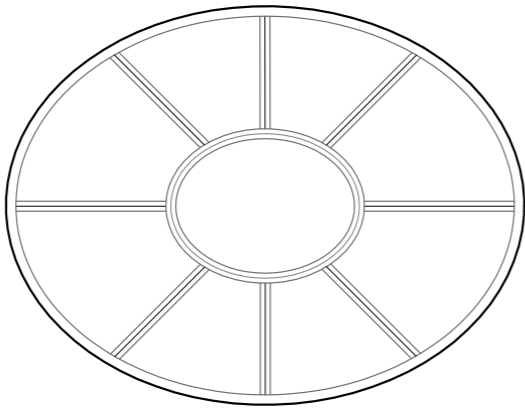

Freedom to create

# FREEDOM TO CREATE

Lift and Slide  
Sill Options



## Standard Track Option

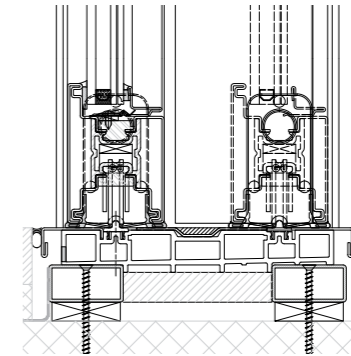

Our standard track provides reliable high performance against the most demanding elements with an integrated weep system. Between the stainless steel rails we provide a color matched cover so uniformity exists throughout.



## Flush Track Option

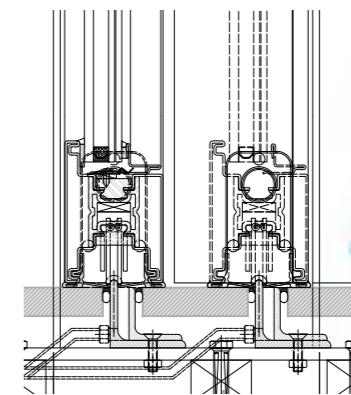

If concealment is your desired effect we have the perfect solution. A near seamless transition between floor coverings and stainless steel track is possible. The flush track's unique engineering provides adjustment screws allowing for a perfectly level installation. Included is a practical water drainage system.

Freedom to create

# FREEDOM TO CREATE

Door  
Sill Options

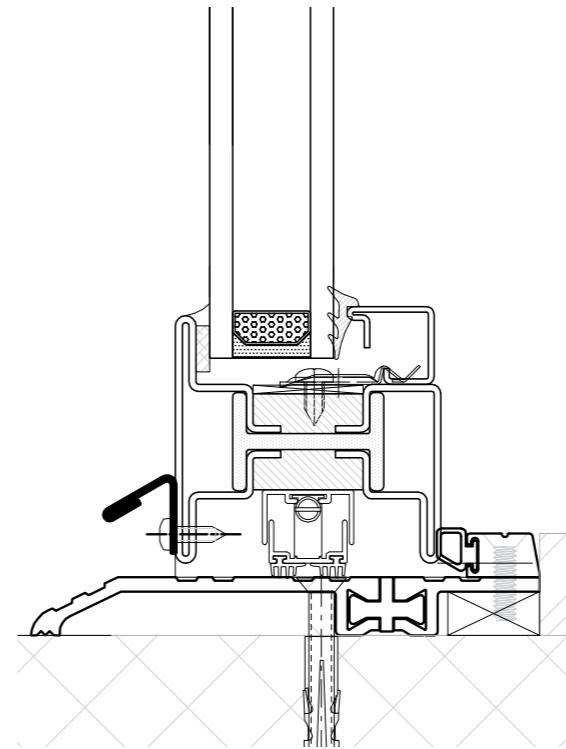

## Outswing Option



Simple yet functional, our outswing door thresholds provide a weather tight seal against the elements. Available in a range of sizes and configurations to suit any sill condition. Finishes include anodized aluminum, bronze, stainless steel, corten, powder coated and a variety of custom finishes and materials.

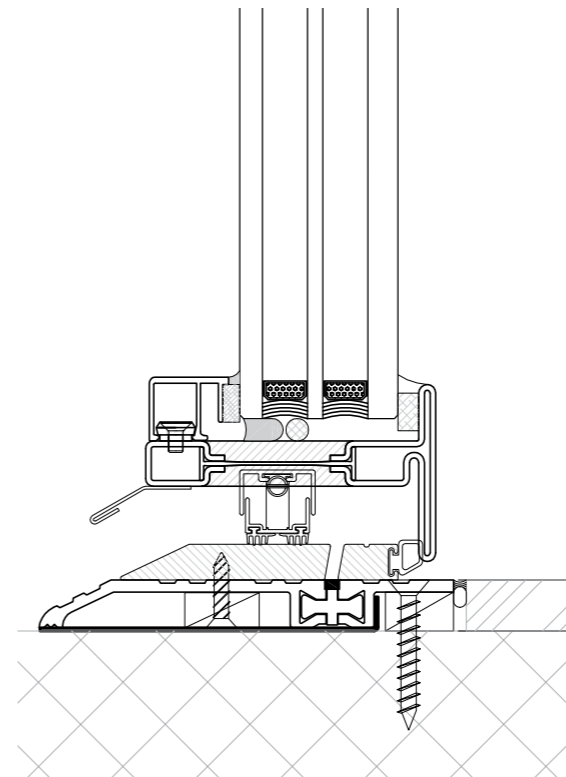

## Inswing Option



Our inswing thresholds are a perfect solution for a weather tight application. They have been customized and include a built in weep system, an integrated pan, and rubber gasketing which provide ultimate performance. Available in a range of sizes and configurations to suit any sill condition. Finishes include anodized aluminum, bronze, stainless steel, corten, powder coated and a variety of custom finishes and materials.

# SERVICES

Our Customer Service Goal:



Focus on the point where what we do best and what our customers want most intersect

We know that if we leave the right impression that our customers will never leave us. This is why we strive to always provide more than what they ever expect. These services are found in detailed shop drawings, installation service assistance, job-site fine tuning, sample and mock-up fabrication, and collaboration meetings.



# SERVICES

## Feasibility Studies

All details are painstakingly considered and communicated in exactness. There is no room for error so an exhaustive approach in vetting out all needs and requirements is made. Architects, builders, and other subcontractors are brought together to ensure Brombal's products fit seamlessly within the project scope.

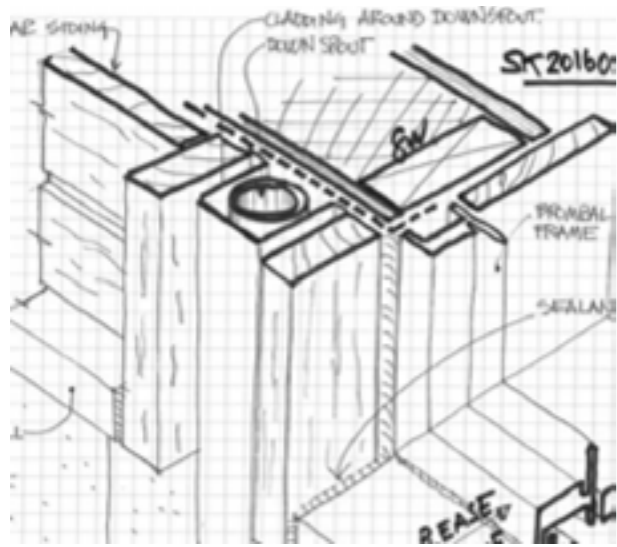

## Installation and Field Services

We have a saying at Brombal that 50% of the quality is in the installation. We take this important process seriously because it must be done right. This is why we provide installation assistance so we can guarantee perfection.

In addition our skilled service technicians are available to fine tune products prior to the client moving in... it's what we call "white glove service."

WELL DONE IS BETTER THAN WELL SAID.



# SERVICES

## Shop Drawings

In order to provide the most accurate and detailed shop drawings we hold pre-shop drawing meetings with the architect and include their head, jamb, sill conditions showing complete integration of Brombal's systems within the building envelope.

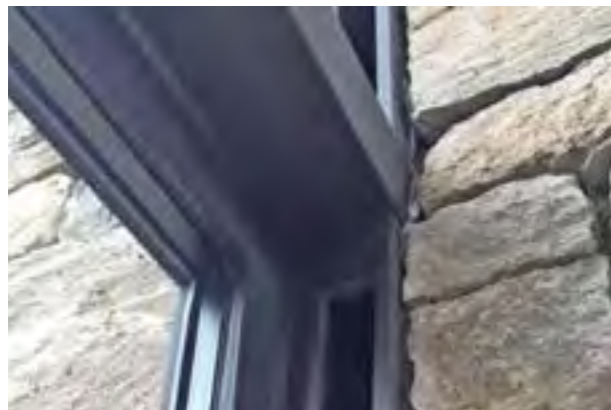
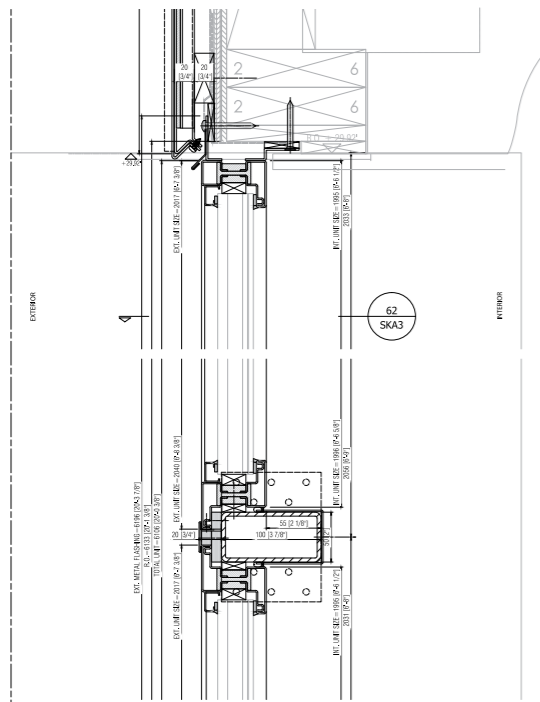

## Samples and Mock-Ups

Providing an accurate portrayal of the window and door systems through sample and mock-up submission is critical in communicating expectations and improving product design. Brombal wants clients to see, feel, test, and have complete confidence in the products they are receiving. This process is accelerated during the design phase well in advance of final product fabrication.



WHEN  
PERFORMANCE  
AND DESIGN  
FLEXIBILITY MEET  
QUALITY... SYSTEMS  
ARE DEFINED

Each project is unique thus requiring the fenestration systems to be up to the challenge. This requires Brombal and their partners to offer a variety of systems that perform as best in class while maintaining flexibility in design. There are hundreds of profile choices and combinations to develop a system that fits your project perfectly.



OS2

OS2 65  
OS2 77

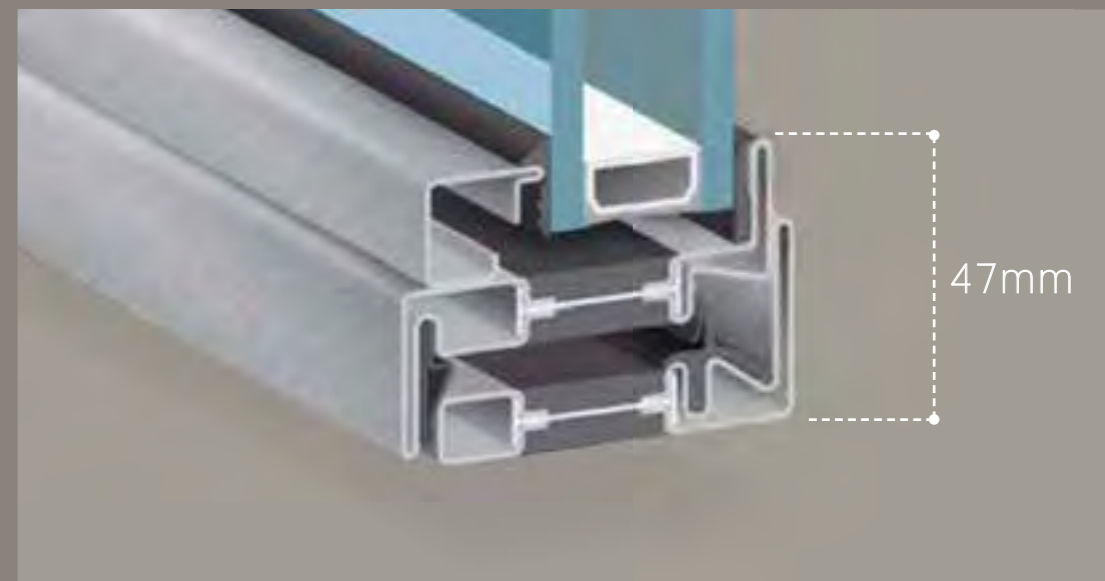

An innovative door and window system with minimal sightlines.

The OS2 system was developed and designed to provide historical and monumental buildings with door and window frames that mimic traditional steel windows used in the 19th through mid 20th century. With narrow sections and the use of materials like galvanized steel, the OS2 system is also a perfect fit for traditional architecture, but is versatile enough to work in contemporary architecture as well. This system exceeds the current energy standards by use of thermal break as well as dual and triple pane glazing options while also being a design and style leader. Along with the energy efficiency the OS2 produces, it has gone through rigorous FL hurricane testing proving the functionality and durability of this narrow sightline product. The OS2 system includes a complete range of accessories that enables it to be used in a wide range of product offerings.

# OS2 65

- 1 glazing bead
- 2 internal and external rebate
- 3 internal rebate seal
- 4 polyurethane
- 5 polyamide break
- 6 frame with weep system seal
- 7 maximum glazing pocket of 43mm (1 11/16")

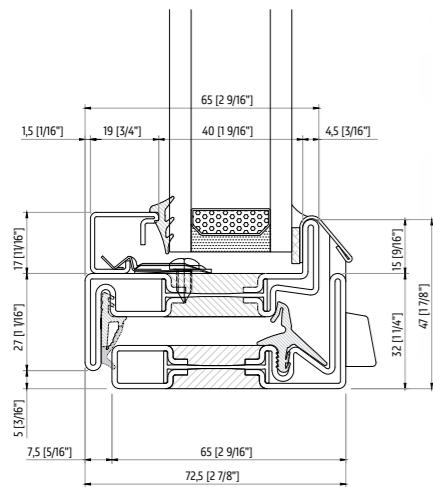

## profiles

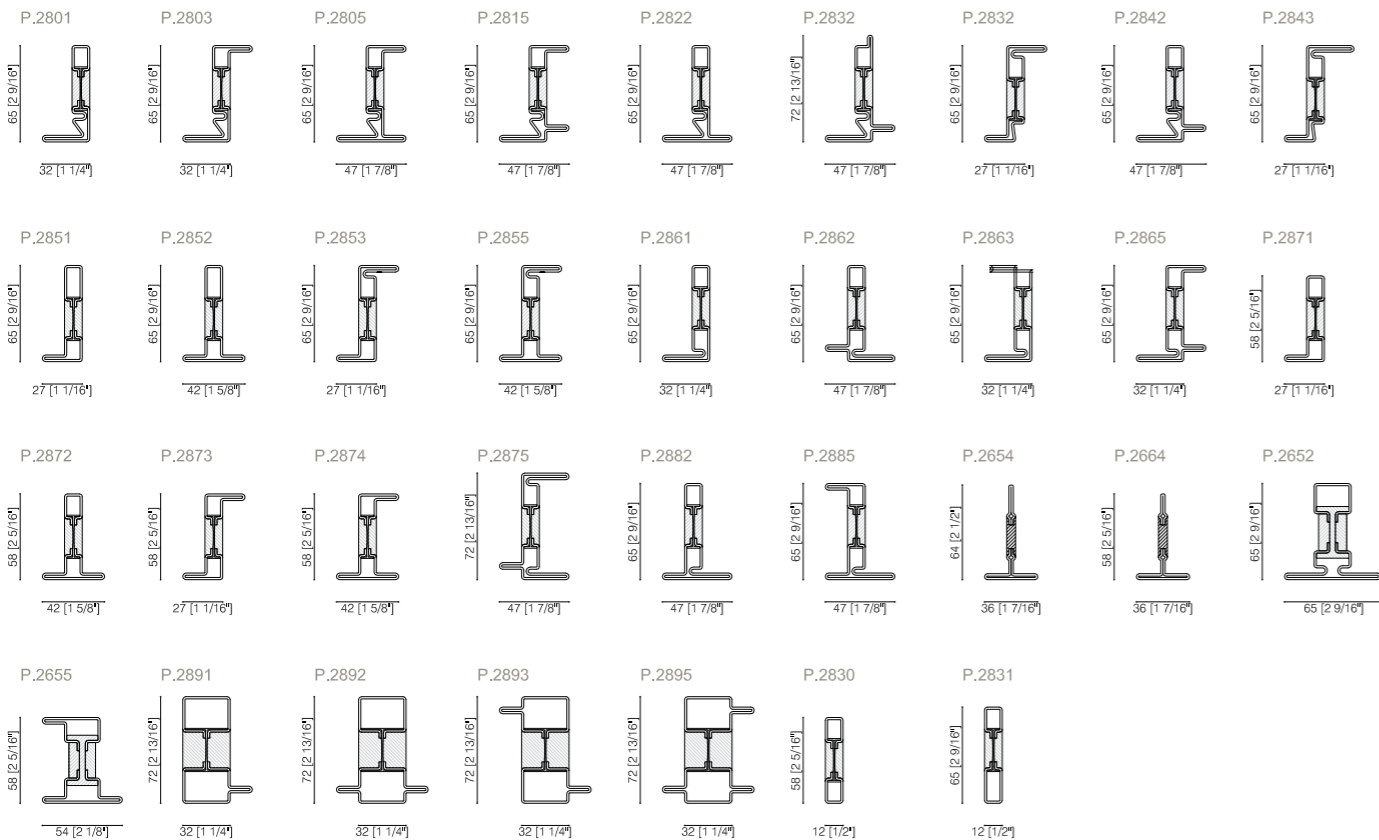

## OS2 65 configurations

Fixed window



Single casement, French casement, Awning, Hopper, Pivot

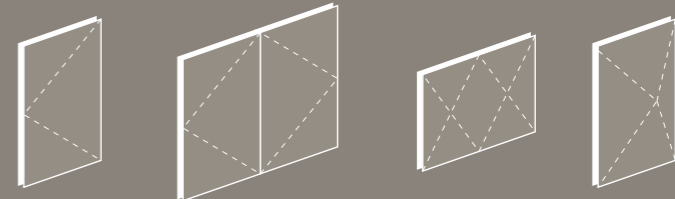

Hinged Doors including single and French

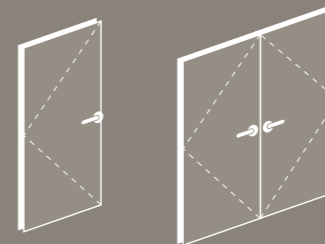

Bi-fold Doors Slider Doors

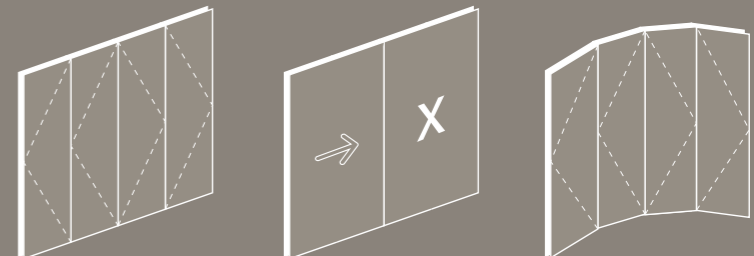

Arched top, Shaped and Curved units

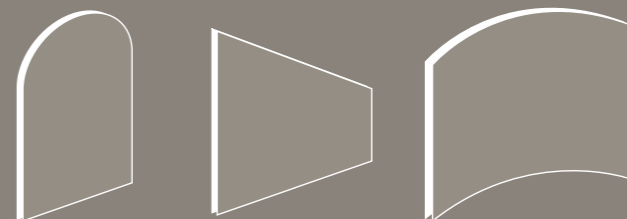

Composite units and Corner configurations for unobstructed views

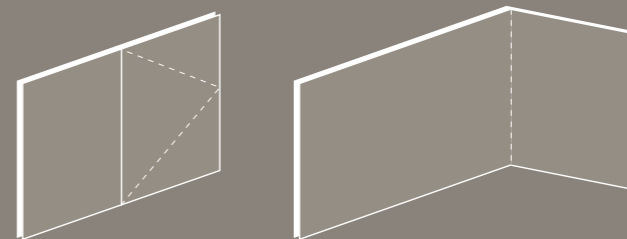

# metal

 available in GALVANIZED STEEL - CORTEN STEEL - STAINLESS STEEL - BRASS

### P.2607

square glazing bead



- FIXED FRAME 20mm (13/16") leg interior glazing bead
- FIXED FRAME 15mm (9/16") leg interior glazing bead
- WINDOW/DOOR open in interior glazing bead
- WINDOW/DOOR open in exterior glazing bead
- WINDOW/DOOR open out interior glazing bead
- WINDOW/DOOR open out exterior glazing bead

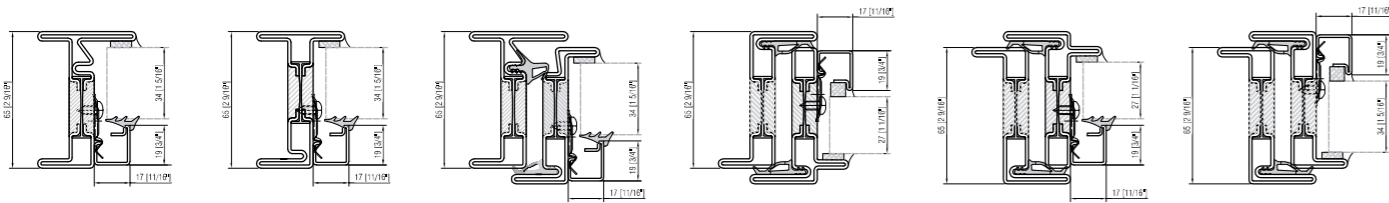

### P.2606

square glazing bead



- FIXED FRAME 20mm (13/16") leg interior glazing bead
- FIXED FRAME 15mm (9/16") leg interior glazing bead
- WINDOW/DOOR open in interior glazing bead
- WINDOW/DOOR open in exterior glazing bead
- WINDOW/DOOR open out interior glazing bead
- WINDOW/DOOR open out exterior glazing bead

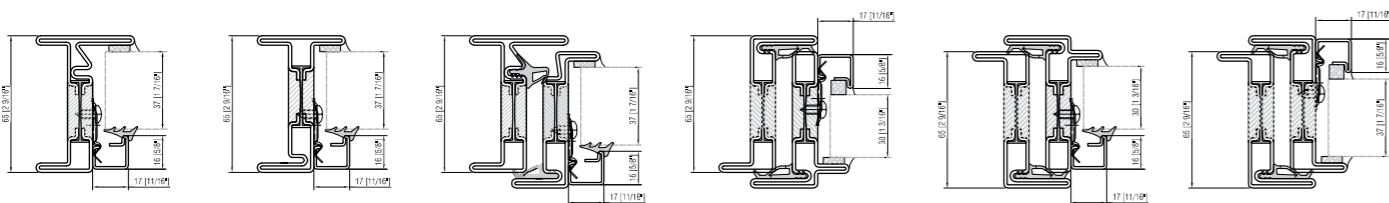

### P.2015

square glazing bead



- FIXED FRAME 20mm (13/16") leg interior glazing bead
- FIXED FRAME 15mm (9/16") leg interior glazing bead
- WINDOW/DOOR open in interior glazing bead
- WINDOW/DOOR open in exterior glazing bead
- WINDOW/DOOR open out interior glazing bead
- WINDOW/DOOR open out exterior glazing bead

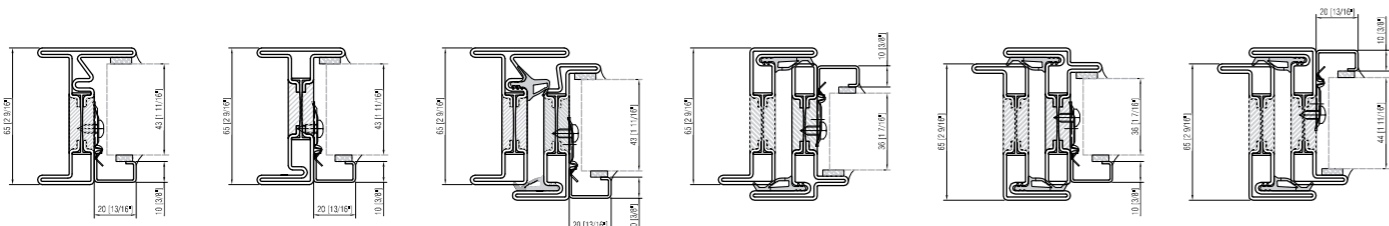

# metal

 available in GALVANIZED STEEL - CORTEN STEEL - STAINLESS STEEL - BRASS

### P.2629

sloped glazing bead



- FIXED FRAME 20mm (13/16") leg interior glazing bead
- FIXED FRAME 15mm (9/16") leg interior glazing bead
- WINDOW/DOOR open in interior glazing bead
- WINDOW/DOOR open in exterior glazing bead
- WINDOW/DOOR open out interior glazing bead
- WINDOW/DOOR open out exterior glazing bead

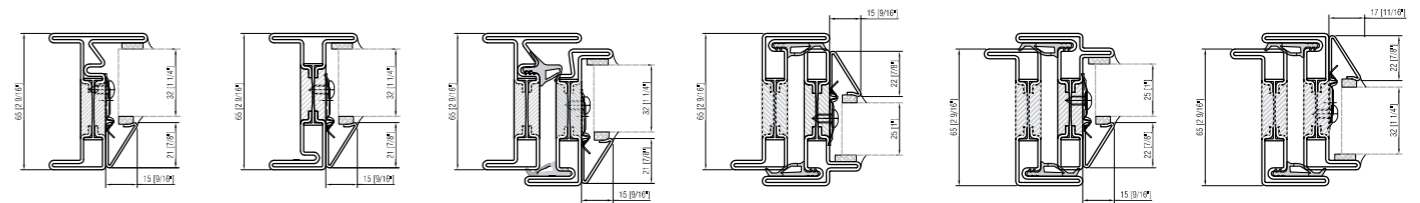

### P.2028

gothic glazing bead

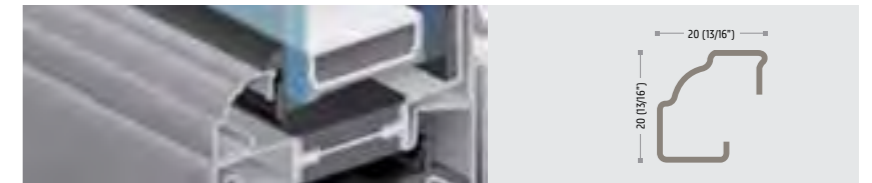

- FIXED FRAME 20mm (13/16") leg interior glazing bead
- FIXED FRAME 15mm (9/16") leg interior glazing bead
- WINDOW/DOOR open in interior glazing bead
- WINDOW/DOOR open in exterior glazing bead
- WINDOW/DOOR open out interior glazing bead
- WINDOW/DOOR open out exterior glazing bead

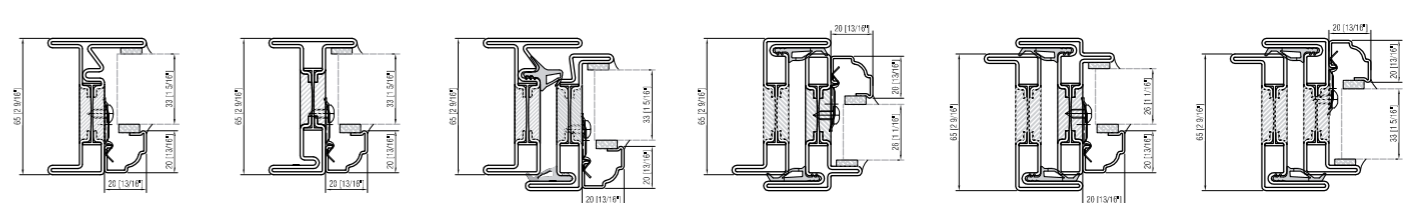

### P.2038

### P.2638

L glazing bead

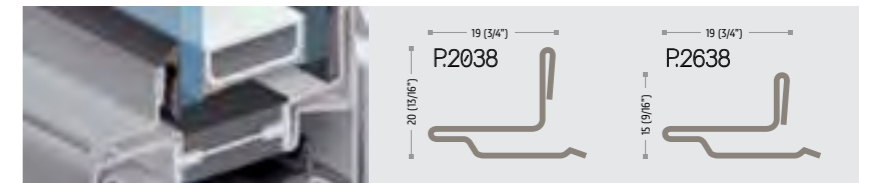

- FIXED FRAME 20mm (13/16") leg interior glazing bead
- FIXED FRAME 15mm (9/16") leg interior glazing bead
- WINDOW/DOOR open in interior glazing bead
- WINDOW/DOOR open in exterior glazing bead
- WINDOW/DOOR open out interior glazing bead
- WINDOW/DOOR open out exterior glazing bead

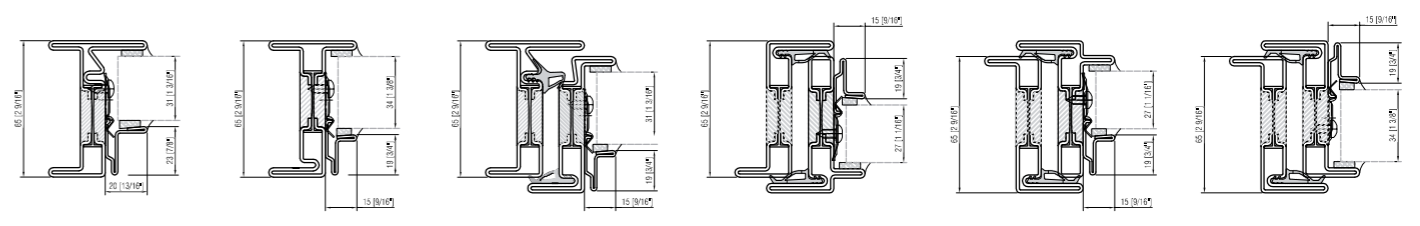

# aluminum

available for  
GALVANIZED STEEL POWDER COATED

PA.2607  
square glazing bead



- FIXED FRAME 20mm (13/16") leg interior glazing bead
- FIXED FRAME 15mm (9/16") leg interior glazing bead
- WINDOW/DOOR open in interior glazing bead
- WINDOW/DOOR open in exterior glazing bead
- WINDOW/DOOR open out interior glazing bead
- WINDOW/DOOR open out exterior glazing bead

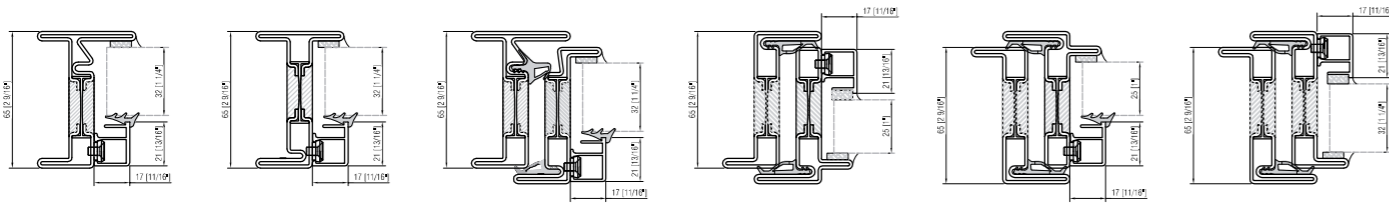

PA.2608  
square glazing bead



- FIXED FRAME 20mm (13/16") leg interior glazing bead
- FIXED FRAME 15mm (9/16") leg interior glazing bead
- WINDOW/DOOR open in interior glazing bead
- WINDOW/DOOR open in exterior glazing bead
- WINDOW/DOOR open out interior glazing bead
- WINDOW/DOOR open out exterior glazing bead

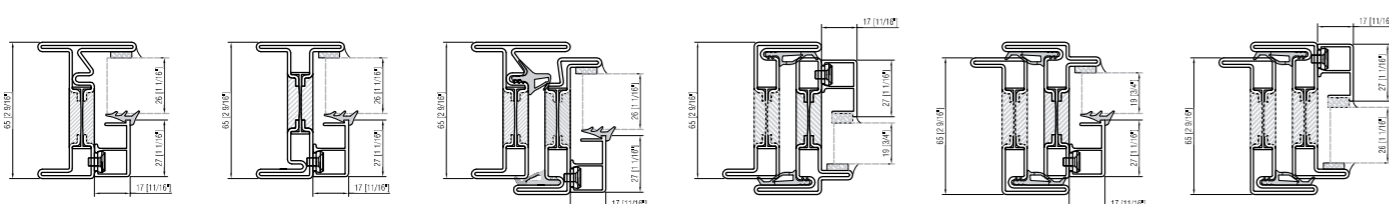

PA.2629  
sloped glazing bead



- FIXED FRAME 20mm (13/16") leg interior glazing bead
- FIXED FRAME 15mm (9/16") leg interior glazing bead
- WINDOW/DOOR open in interior glazing bead
- WINDOW/DOOR open in exterior glazing bead
- WINDOW/DOOR open out interior glazing bead
- WINDOW/DOOR open out exterior glazing bead

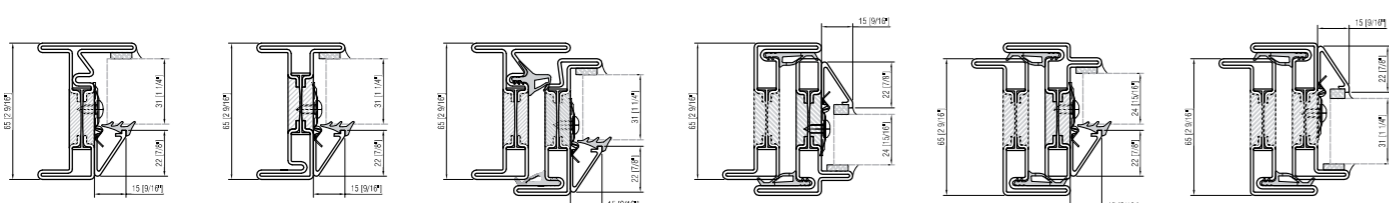

# aluminum

available for  
GALVANIZED STEEL POWDER COATED

PA.2038  
PA.2638  
L glazing bead

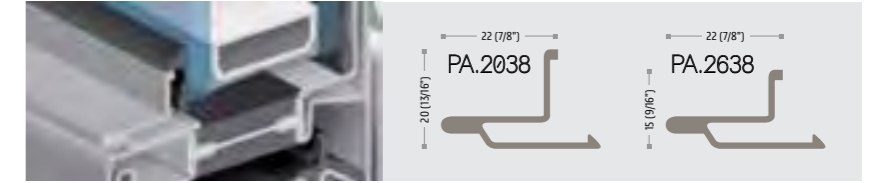

- FIXED FRAME 20mm (13/16") leg interior glazing bead
- FIXED FRAME 15mm (9/16") leg interior glazing bead
- WINDOW/DOOR open in interior glazing bead
- WINDOW/DOOR open in exterior glazing bead
- WINDOW/DOOR open out interior glazing bead
- WINDOW/DOOR open out exterior glazing bead

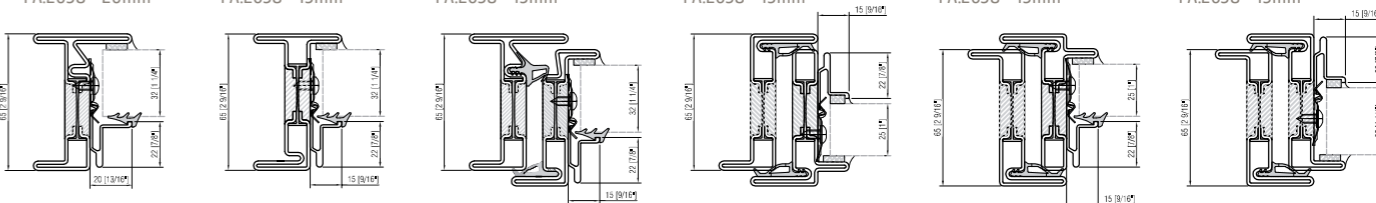

PA.2640  
square glazing bead



- FIXED FRAME 20mm (13/16") leg interior glazing bead
- FIXED FRAME 15mm (9/16") leg interior glazing bead
- WINDOW/DOOR open in interior glazing bead
- WINDOW/DOOR open in exterior glazing bead
- WINDOW/DOOR open out interior glazing bead
- WINDOW/DOOR open out exterior glazing bead

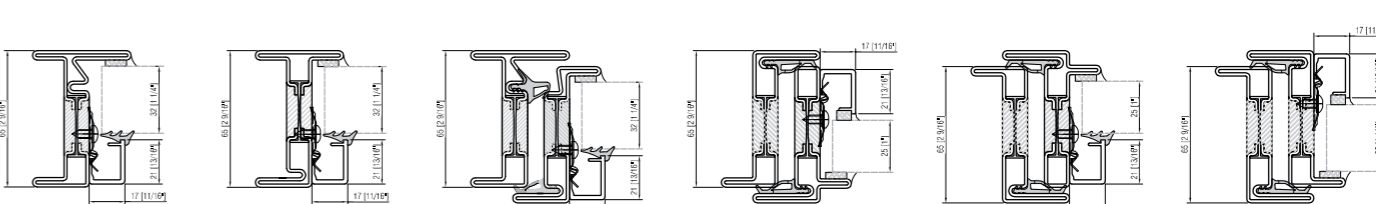

PA.2641  
square glazing bead



- FIXED FRAME 20mm (13/16") leg interior glazing bead
- FIXED FRAME 15mm (9/16") leg interior glazing bead
- WINDOW/DOOR open in interior glazing bead
- WINDOW/DOOR open in exterior glazing bead
- WINDOW/DOOR open out interior glazing bead
- WINDOW/DOOR open out exterior glazing bead

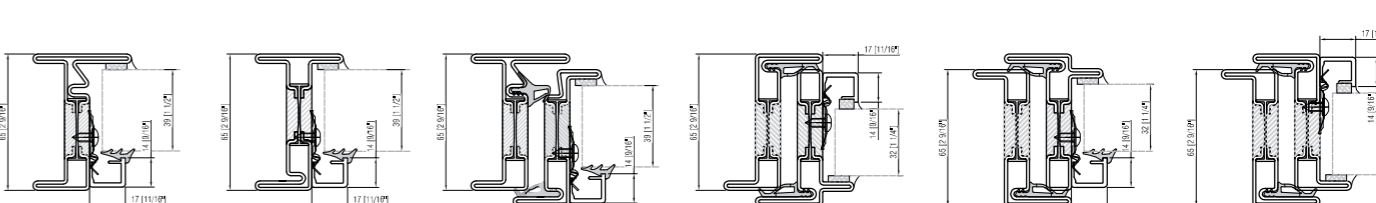

# metal

available in  
GALVANIZED STEEL - CORTEN STEEL - STAINLESS STEEL - BRASS

FLAT SDL AVAILABLE FOR:

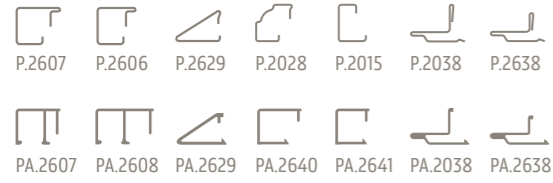

SLOPED SDL AVAILABLE FOR:

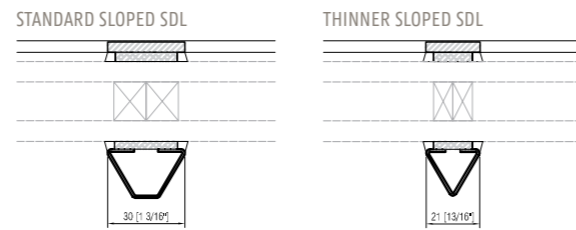

GOTHIC SDL AVAILABLE FOR:

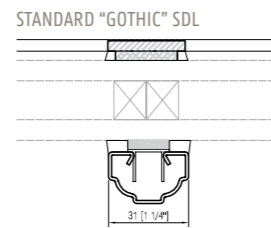

TUBE SDL AVAILABLE FOR:

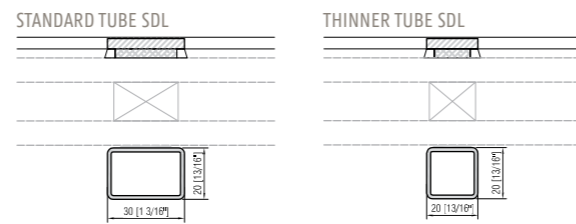

TUBE SDL AVAILABLE FOR:

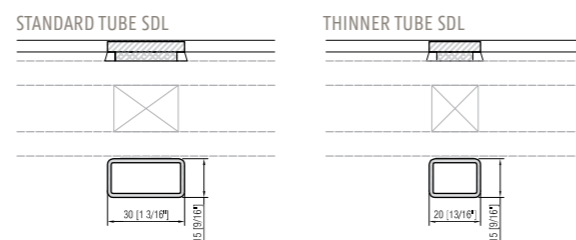

# aluminum

available for  
GALVANIZED STEEL POWDER COATED

SLOPED SDL AVAILABLE FOR:

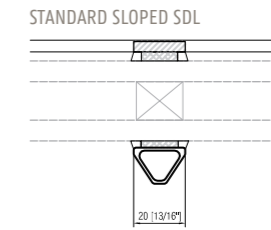

TUBE SDL AVAILABLE FOR:

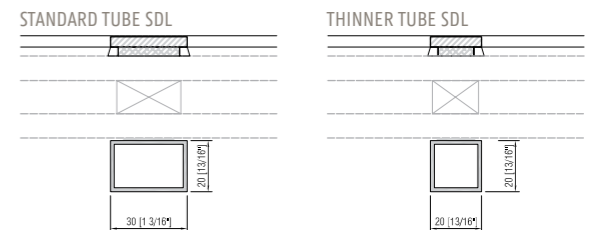

TUBE SDL AVAILABLE FOR:

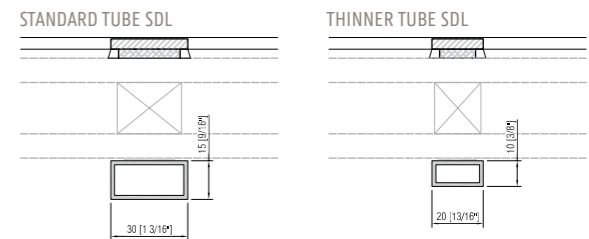

# OS2 77

- 1 glazing bead
- 2 internal and external rebate
- 3 internal rebate seal
- 4 polyurethane
- 5 polyamide break
- 6 frame with weep system seal
- 7 maximum glazing pocket of 55mm (2 3/16")

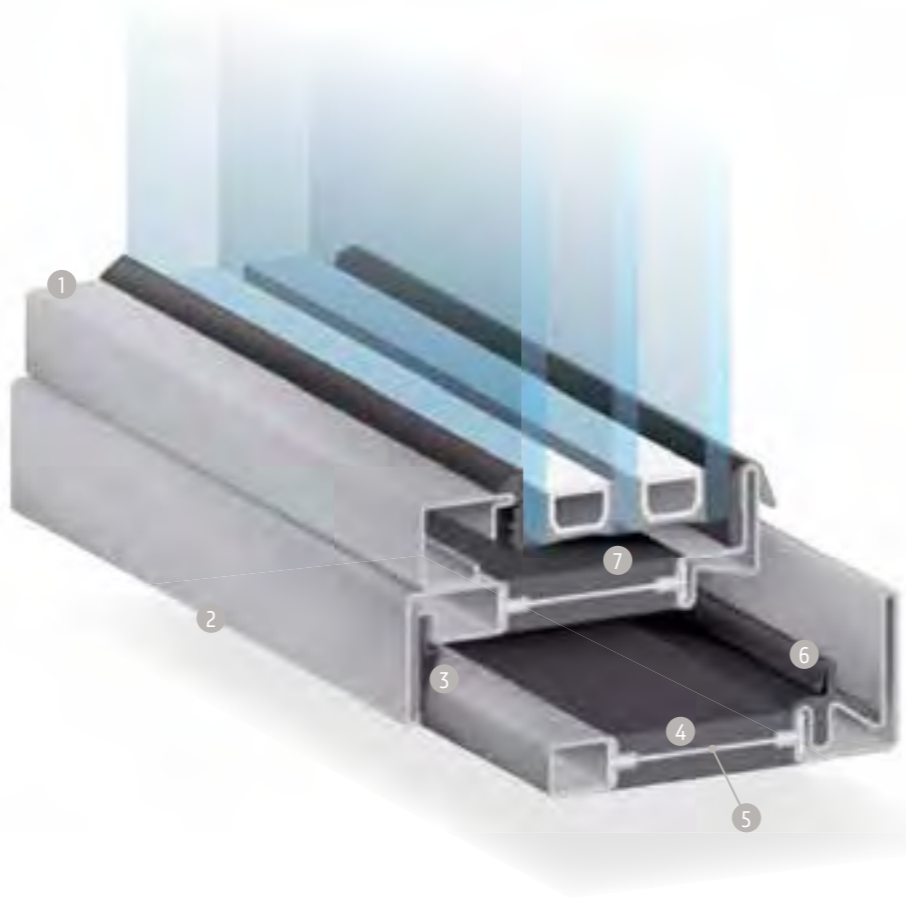
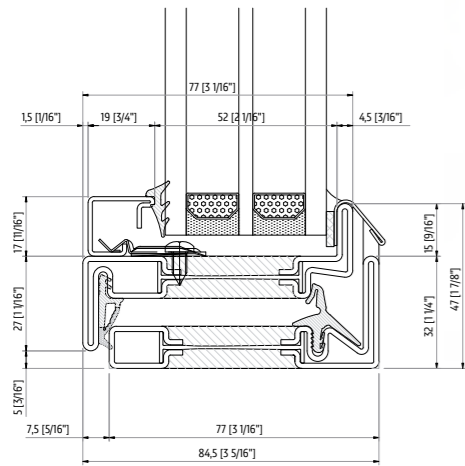

## profiles

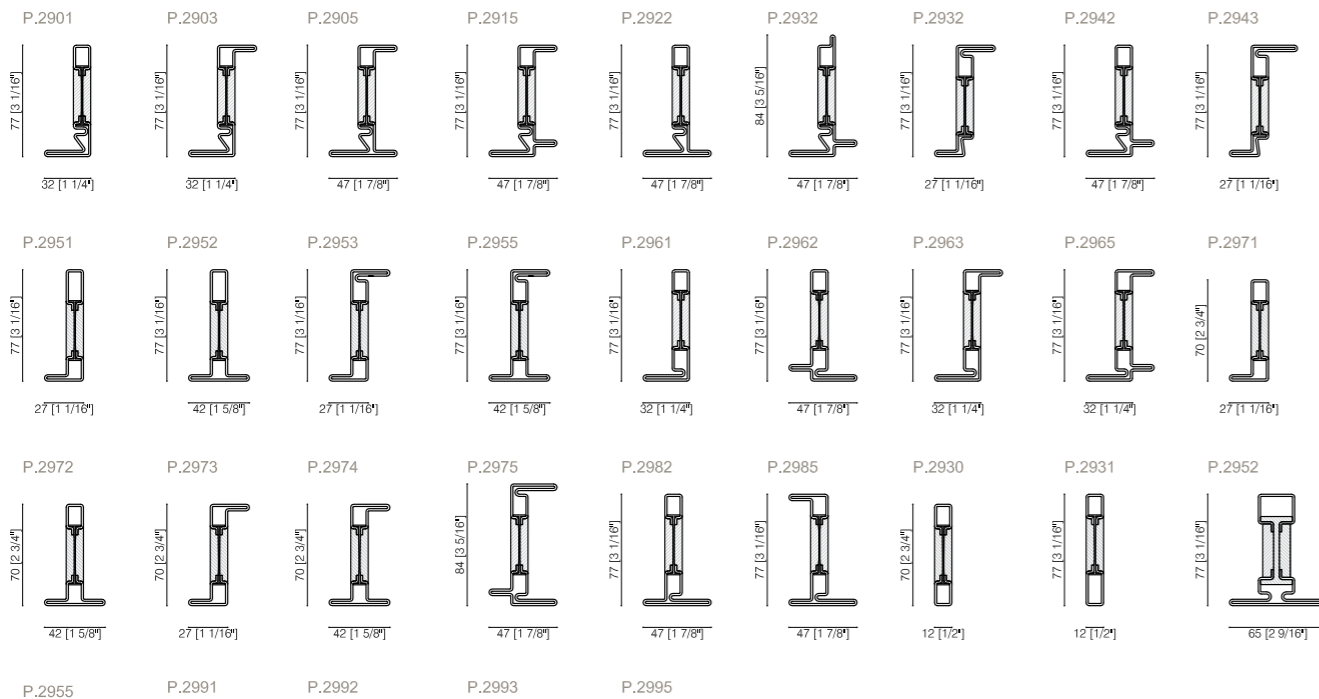

## OS2 77 configurations

Fixed window



Single casement, French casement, Awning, Hopper, Pivot

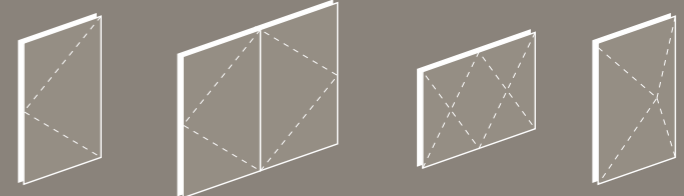

Hinged Doors including single and French

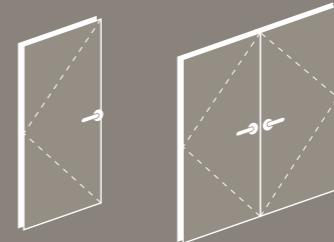

Bi-fold Doors Slider Doors

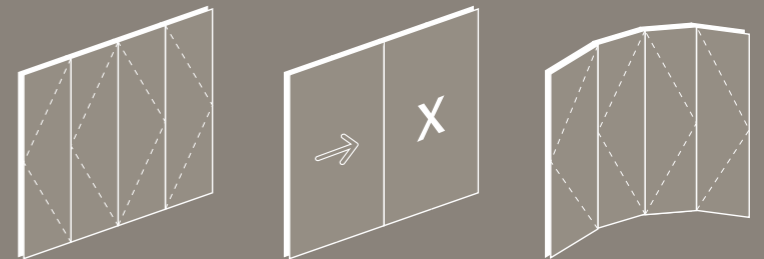

Arched top, Shaped and Curved units

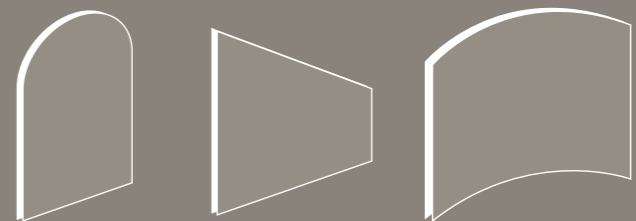

Composite units and Corner configurations for unobstructed views

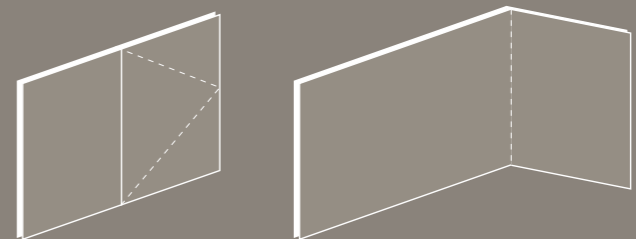



metal available in GALVANIZED STEEL - CORTEN STEEL - STAINLESS STEEL - BRASS

P.2607 square glazing bead



- FIXED FRAME 20mm (13/16") leg interior glazing bead
- FIXED FRAME 15mm (9/16") leg interior glazing bead
- WINDOW/DOOR open in interior glazing bead
- WINDOW/DOOR open in exterior glazing bead
- WINDOW/DOOR open out interior glazing bead
- WINDOW/DOOR open out exterior glazing bead

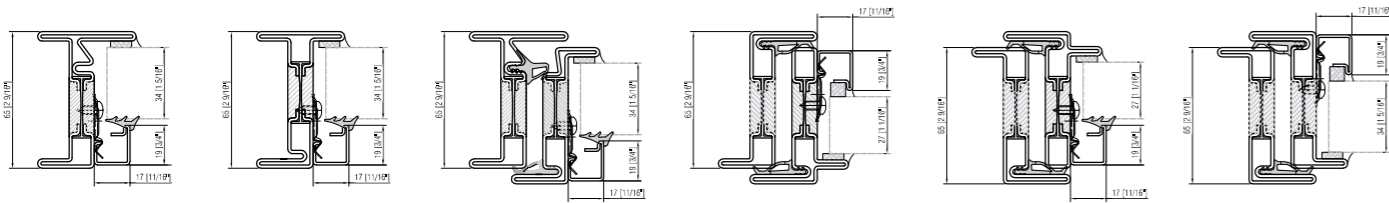

P.2606 square glazing bead



- FIXED FRAME 20mm (13/16") leg interior glazing bead
- FIXED FRAME 15mm (9/16") leg interior glazing bead
- WINDOW/DOOR open in interior glazing bead
- WINDOW/DOOR open in exterior glazing bead
- WINDOW/DOOR open out interior glazing bead
- WINDOW/DOOR open out exterior glazing bead

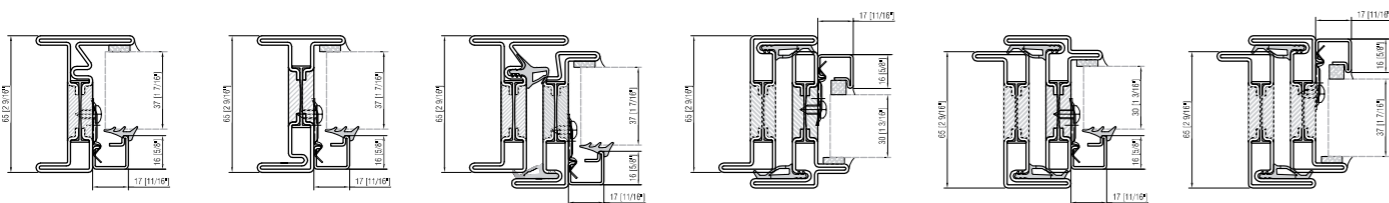

P.2015 square glazing bead



- FIXED FRAME 20mm (13/16") leg interior glazing bead
- FIXED FRAME 15mm (9/16") leg interior glazing bead
- WINDOW/DOOR open in interior glazing bead
- WINDOW/DOOR open in exterior glazing bead
- WINDOW/DOOR open out interior glazing bead
- WINDOW/DOOR open out exterior glazing bead

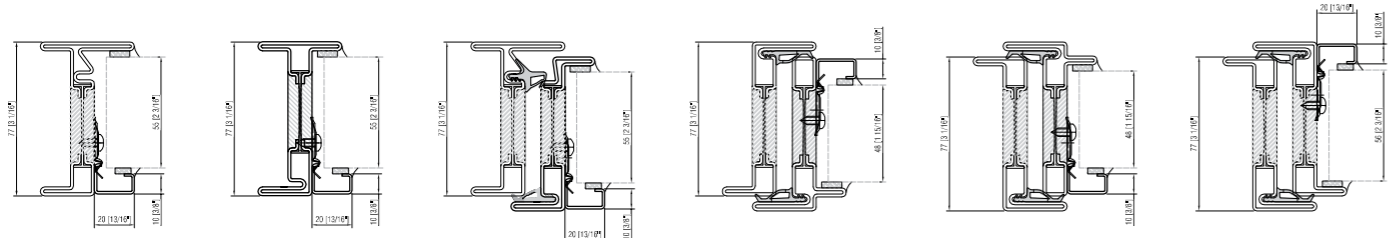

metal available in GALVANIZED STEEL - CORTEN STEEL - STAINLESS STEEL - BRASS

P.2629 sloped glazing bead



- FIXED FRAME 20mm (13/16") leg interior glazing bead
- FIXED FRAME 15mm (9/16") leg interior glazing bead
- WINDOW/DOOR open in interior glazing bead
- WINDOW/DOOR open in exterior glazing bead
- WINDOW/DOOR open out interior glazing bead
- WINDOW/DOOR open out exterior glazing bead

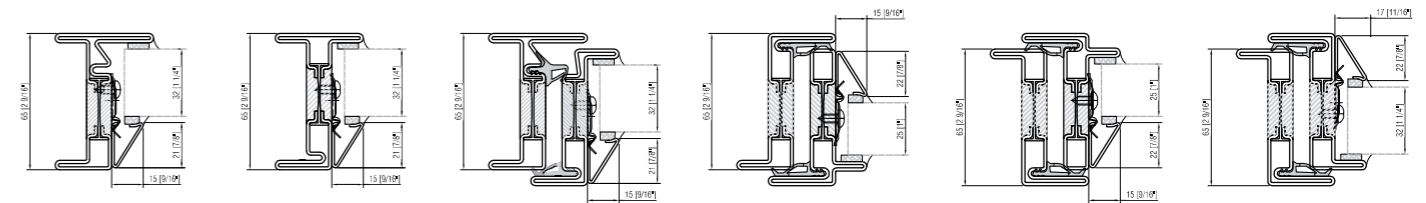

P.2028 gothic glazing bead



- FIXED FRAME 20mm (13/16") leg interior glazing bead
- FIXED FRAME 15mm (9/16") leg interior glazing bead
- WINDOW/DOOR open in interior glazing bead
- WINDOW/DOOR open in exterior glazing bead
- WINDOW/DOOR open out interior glazing bead
- WINDOW/DOOR open out exterior glazing bead

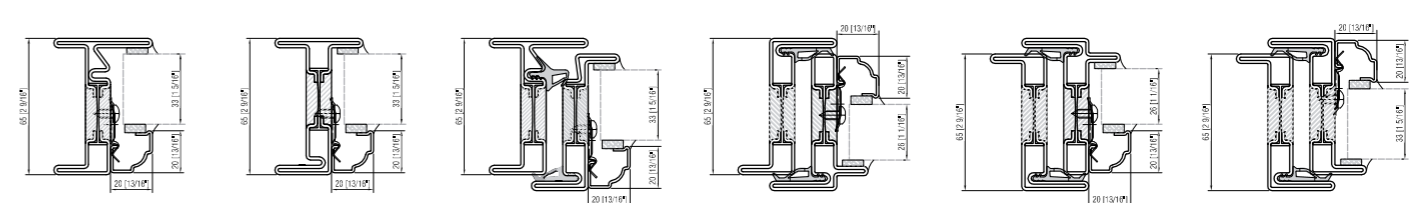

P.2038 P.2638 L glazing bead

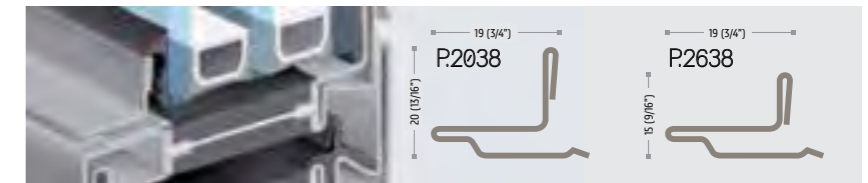

- FIXED FRAME 20mm (13/16") leg interior glazing bead P.2038 - 20mm
- FIXED FRAME 15mm (9/16") leg interior glazing bead P.2638 - 15mm
- WINDOW/DOOR open in interior glazing bead P.2638 - 15mm
- WINDOW/DOOR open in exterior glazing bead P.2638 - 15mm
- WINDOW/DOOR open out interior glazing bead P.2638 - 15mm
- WINDOW/DOOR open out exterior glazing bead P.2638 - 15mm

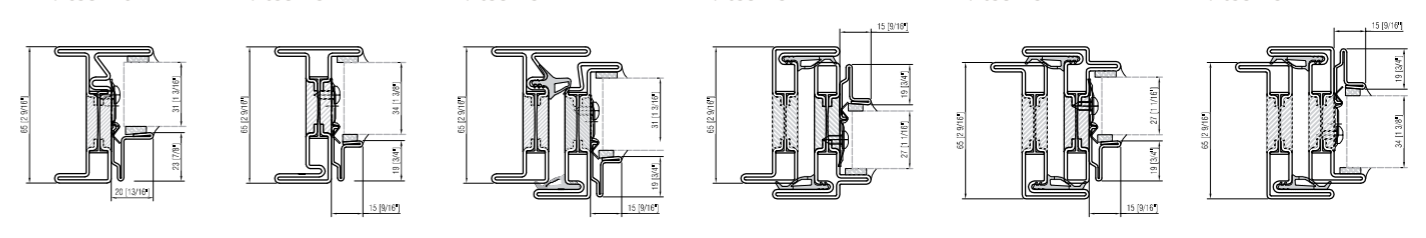

# aluminum

available for  
GALVANIZED STEEL POWDER COATED

PA.2607  
square glazing bead



- FIXED FRAME 20mm (13/16") leg interior glazing bead
- FIXED FRAME 15mm (9/16") leg interior glazing bead
- WINDOW/DOOR open in interior glazing bead
- WINDOW/DOOR open in exterior glazing bead
- WINDOW/DOOR open out interior glazing bead
- WINDOW/DOOR open out exterior glazing bead

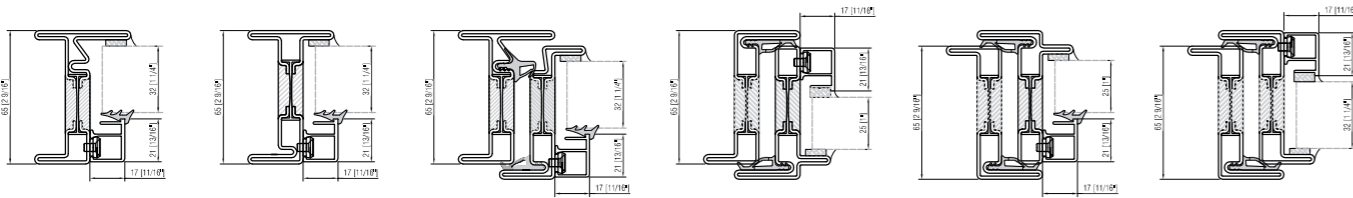

PA.2608  
square glazing bead



- FIXED FRAME 20mm (13/16") leg interior glazing bead
- FIXED FRAME 15mm (9/16") leg interior glazing bead
- WINDOW/DOOR open in interior glazing bead
- WINDOW/DOOR open in exterior glazing bead
- WINDOW/DOOR open out interior glazing bead
- WINDOW/DOOR open out exterior glazing bead

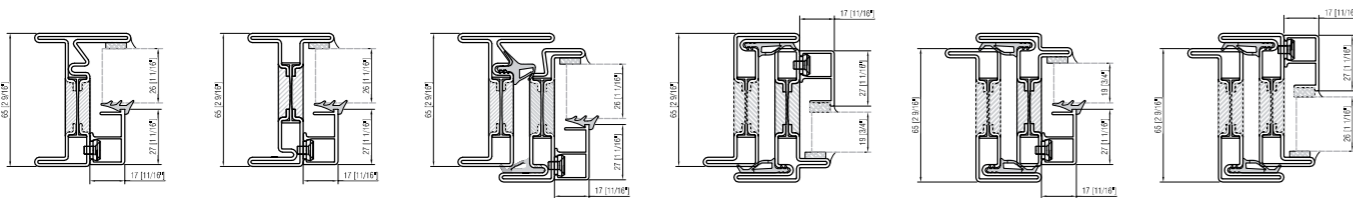

PA.2629  
sloped glazing bead



- FIXED FRAME 20mm (13/16") leg interior glazing bead
- FIXED FRAME 15mm (9/16") leg interior glazing bead
- WINDOW/DOOR open in interior glazing bead
- WINDOW/DOOR open in exterior glazing bead
- WINDOW/DOOR open out interior glazing bead
- WINDOW/DOOR open out exterior glazing bead

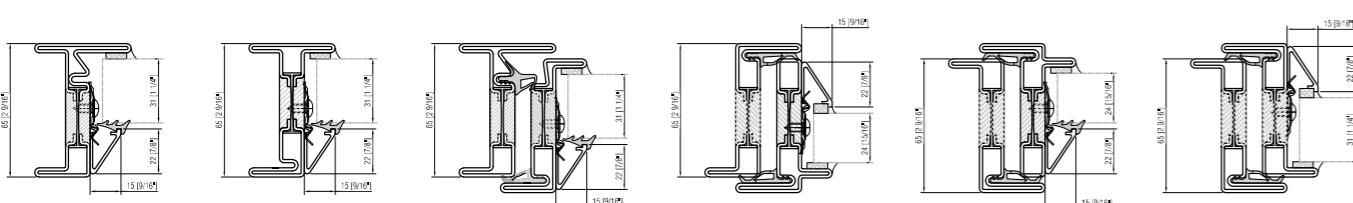

# aluminum

available for  
GALVANIZED STEEL POWDER COATED

PA.2038  
PA.2638  
L glazing bead

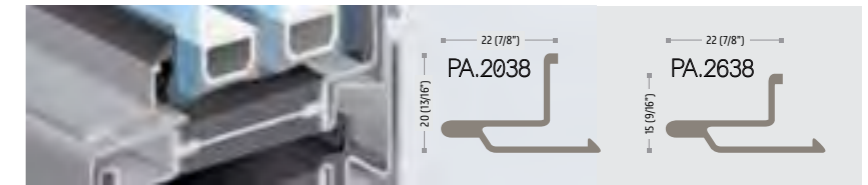

- FIXED FRAME 20mm (13/16") leg interior glazing bead
- FIXED FRAME 15mm (9/16") leg interior glazing bead
- WINDOW/DOOR open in interior glazing bead
- WINDOW/DOOR open in exterior glazing bead
- WINDOW/DOOR open out interior glazing bead
- WINDOW/DOOR open out exterior glazing bead

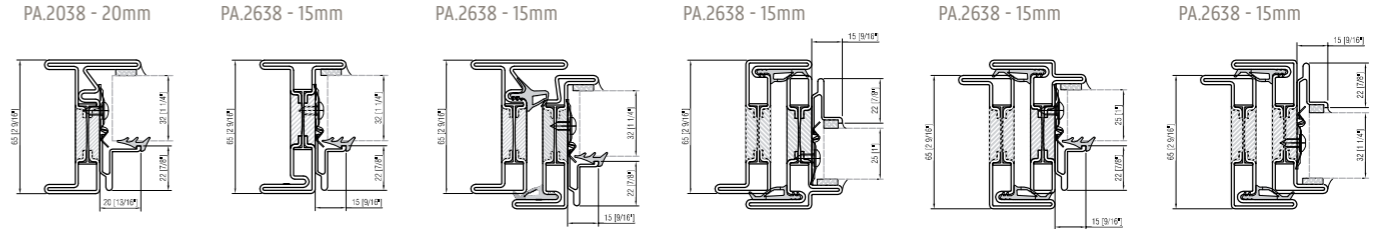

PA.2640  
square glazing bead



- FIXED FRAME 20mm (13/16") leg interior glazing bead
- FIXED FRAME 15mm (9/16") leg interior glazing bead
- WINDOW/DOOR open in interior glazing bead
- WINDOW/DOOR open in exterior glazing bead
- WINDOW/DOOR open out interior glazing bead
- WINDOW/DOOR open out exterior glazing bead

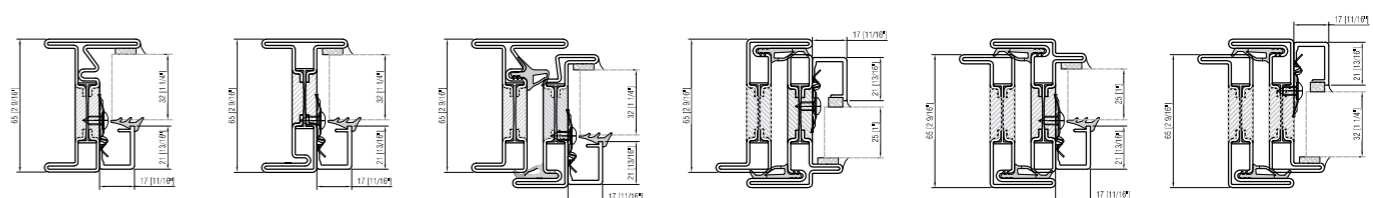

PA.2641  
square glazing bead



- FIXED FRAME 20mm (13/16") leg interior glazing bead
- FIXED FRAME 15mm (9/16") leg interior glazing bead
- WINDOW/DOOR open in interior glazing bead
- WINDOW/DOOR open in exterior glazing bead
- WINDOW/DOOR open out interior glazing bead
- WINDOW/DOOR open out exterior glazing bead

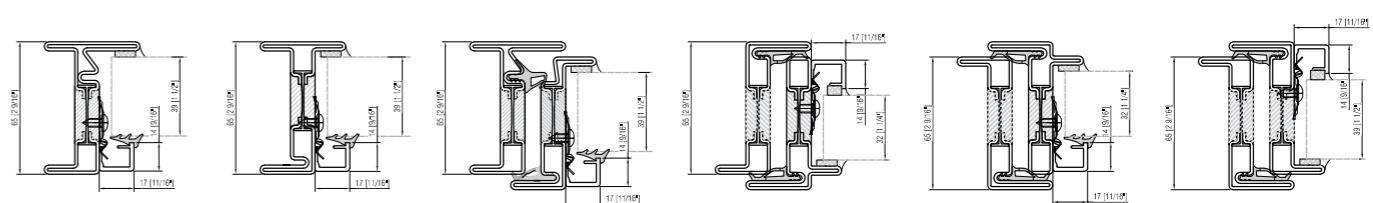

# metal

available in  
GALVANIZED STEEL - CORTEN STEEL - STAINLESS STEEL - BRASS

FLAT SDL AVAILABLE FOR:

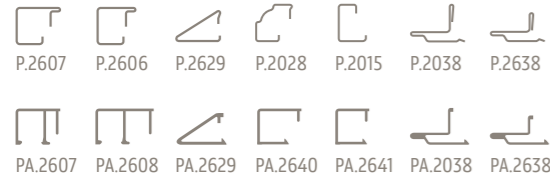

SLOPED SDL AVAILABLE FOR:

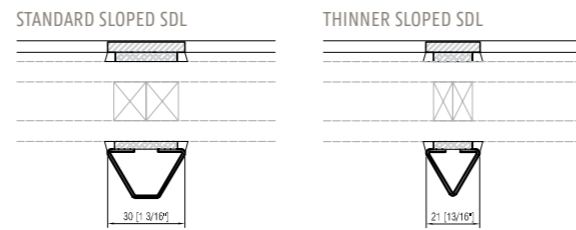

GOTHIC SDL AVAILABLE FOR:

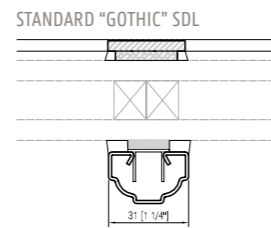

TUBE SDL AVAILABLE FOR:

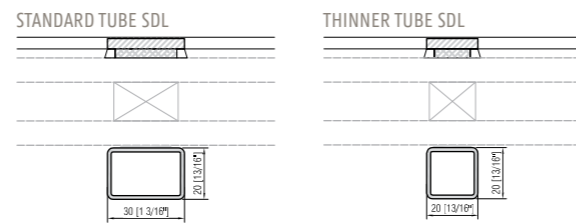

TUBE SDL AVAILABLE FOR:

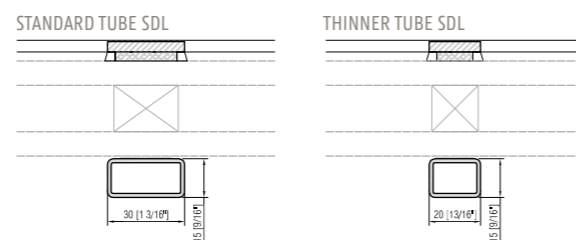

# aluminum

available for  
GALVANIZED STEEL POWDER COATED

SLOPED SDL AVAILABLE FOR:

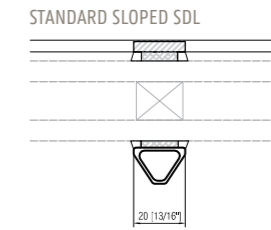

TUBE SDL AVAILABLE FOR:

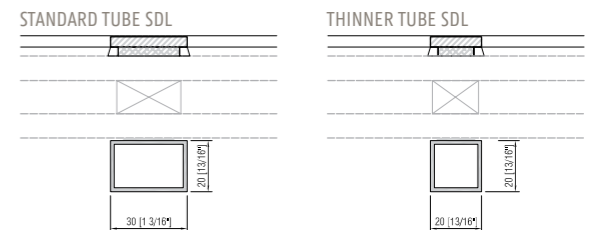

TUBE SDL AVAILABLE FOR:

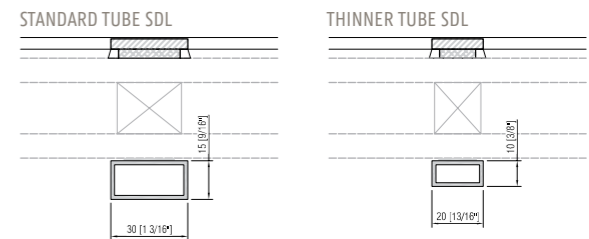

# wood option

AVAILABLE ONLY FOR OUTSWING OPTION WITH EXTERIOR GLAZING BEAD.  
Any wood species available.

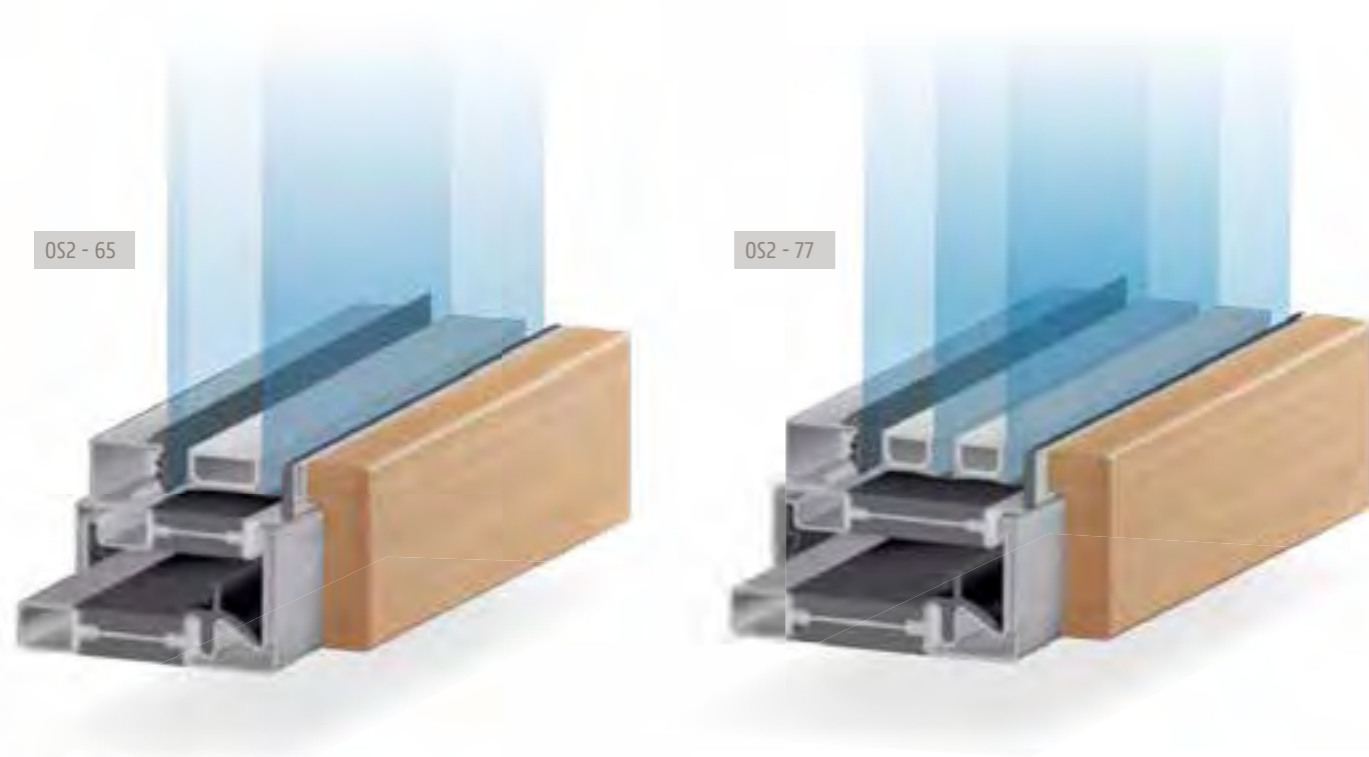

# LUXURY LINE

Available in galvanized steel, stainless steel, CorTen, bronze metals.

## HINGE:

Mechanically fastened fully adjustable hinges (vertical and horizontal).



## GLAZING BEAD:

Welded galvanized steel, stainless steel, bronze and CorTen glazing beads (square, sloped, L, gothic).



## THERMALLY BROKEN:

Masking off of thermal break prior to finishing.



## OTHER:

Grinding smooth of all welds and frame surfaces.



# ESSENTIALS LINE

Available only in galvanized steel.

## HINGE:

Welded to frame hinges (only vertical adjustment).



## GLAZING BEAD:

Welded aluminum square, L or sloped glazing beads.



## THERMALLY BROKEN:

Complete painting of thermal break.



## OTHER:

Slightly less grinding of the frame and welds prior to finishing.



# EBE

EBE 65  
EBE 73  
EBE 85  
EBE STYLE  
EBE METAL WOOD



The technical answer to energy efficiency and product design versatility.

Doors and windows have a very complex role: on one hand they define the design of a building, on the other they separate the internal and external environment. In line with sustainable architecture requirements, they have to guarantee the highest standards of energy saving, maximum comfort, acoustic performance, maximum resistance to weather agents, active and passive safety and low maintenance costs. EBE 65 is the technological answer to the ever demanding building performance requirements. The innovative technological solution, known as "thermal break" that is made of polyamide and polyurethane, allows for highly structural profiles with low visual impact. Moreover, the four materials used – galvanized steel, stainless steel, corten steel and brass – can be combined to taste for the internal and external part of the profile. EBE 65 system meets the most demanding requirements while offering, at the same time, different design solutions. This is possible thanks to its performance features, its wide choice of opening systems and its complete set of system accessories.

# EBE 65

- 1 glazing bead
- 2 maximum glazing pocket of 47mm (1 7/8")
- 3 fitting groove for hardware
- 4 flush on the exterior and rebated on the interior
- 5 frame with weep system and triple gasket
- 6 structural thermal break in polyamide and polyurethane

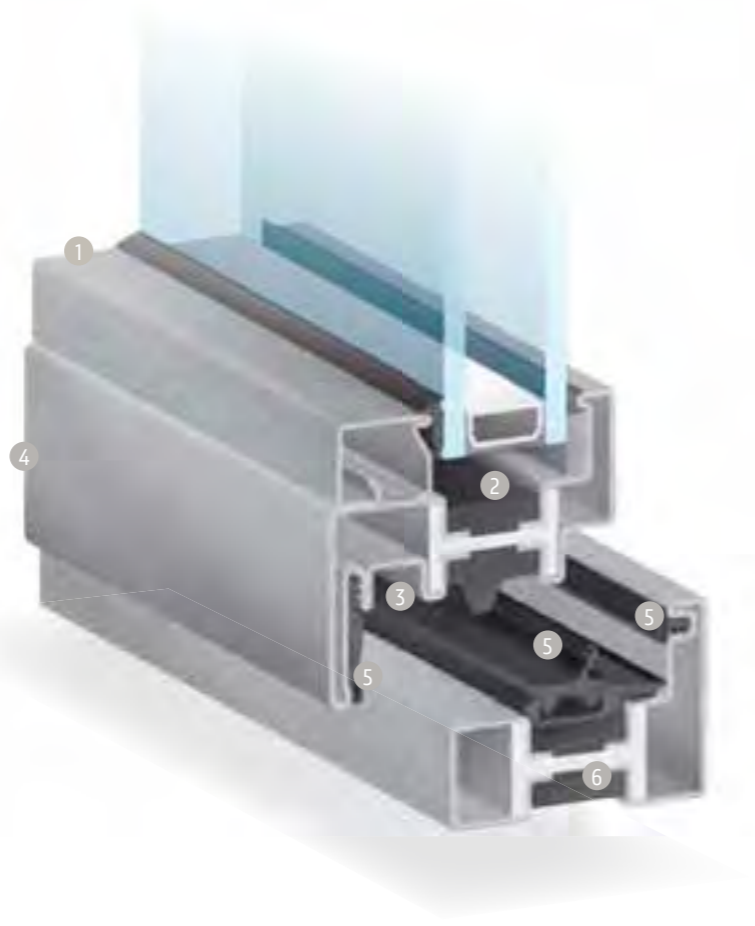
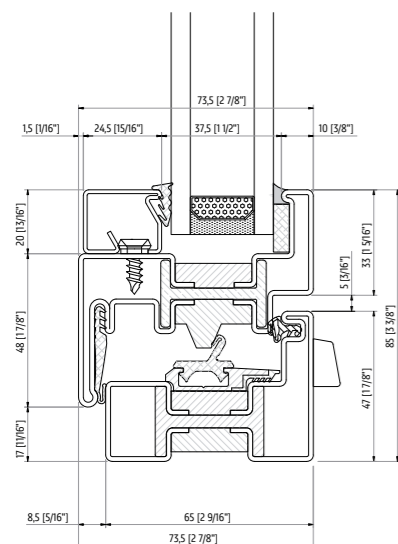

## profiles

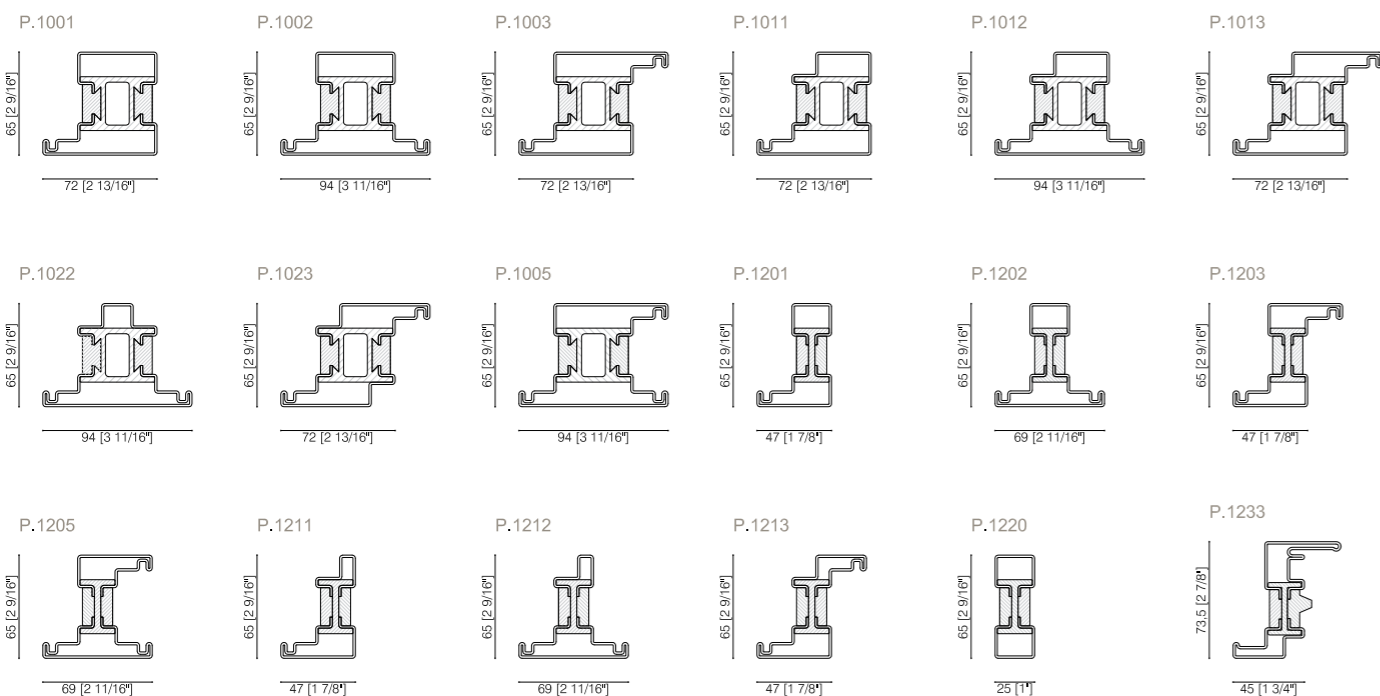

## EBE 65 configurations

Fixed window



Single casement, French casement, Awning, Hopper, Pivot

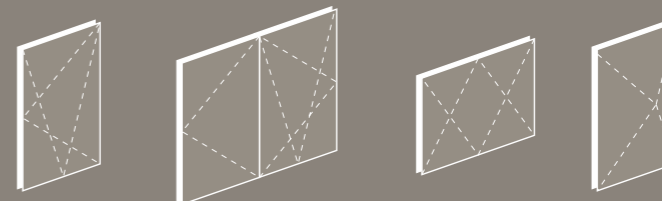

Hinged Doors including single and French Pivot Doors

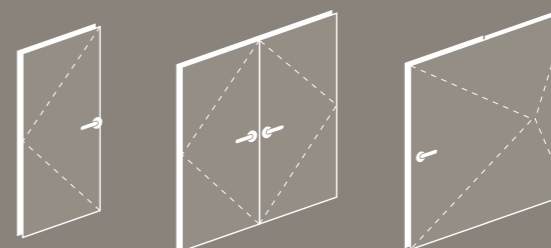

Bi-fold Doors Lift and slide Doors

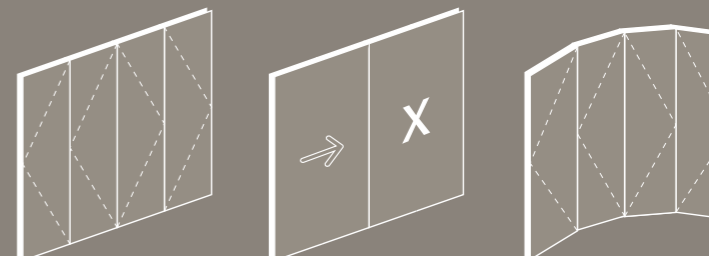

Arched top, Shaped and Curved units

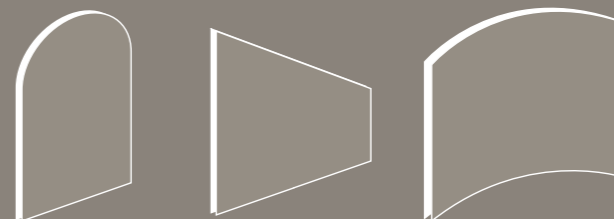

Composite units and Corner configurations for unobstructed views

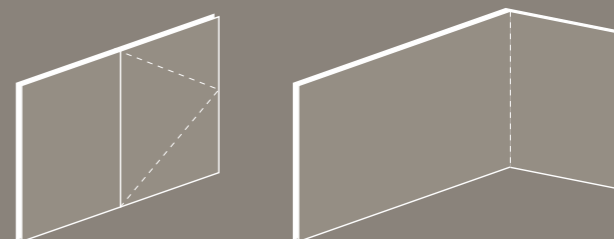

# metal

 available in GALVANIZED STEEL - CORTEN STEEL - STAINLESS STEEL - BRASS

P.1007 square glazing bead



FIXED FRAME interior glazing bead

WINDOW open in interior glazing bead

DOOR open out interior glazing bead

WINDOW open out exterior glazing bead

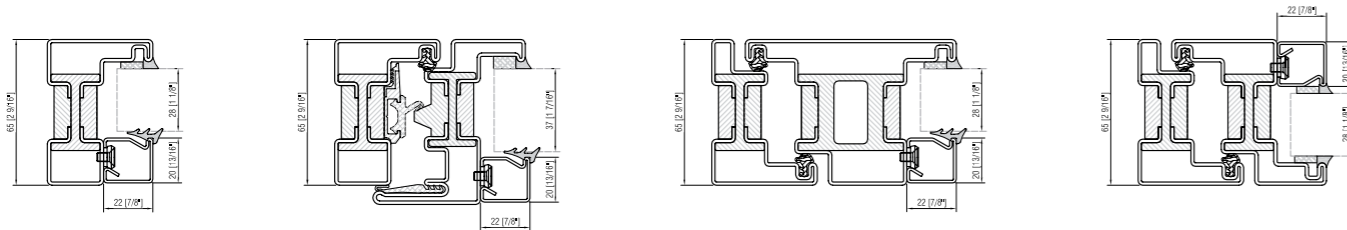

P.2007 square glazing bead



FIXED FRAME interior glazing bead

WINDOW open in interior glazing bead

DOOR open out interior glazing bead

WINDOW open out exterior glazing bead

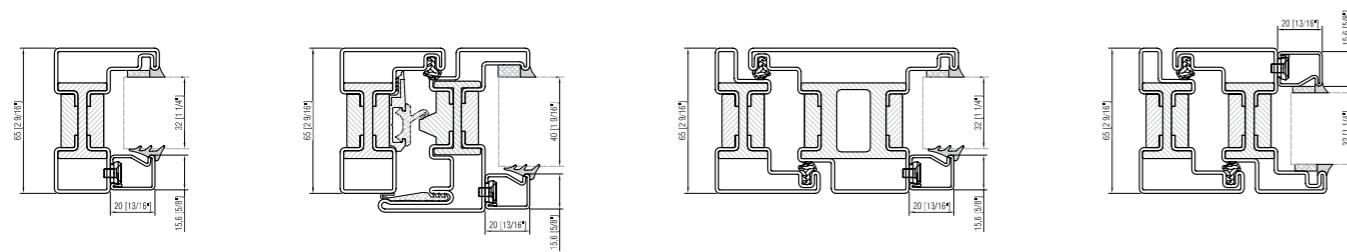

P.2008 square glazing bead



FIXED FRAME interior glazing bead

WINDOW open in interior glazing bead

DOOR open out interior glazing bead

WINDOW open out exterior glazing bead

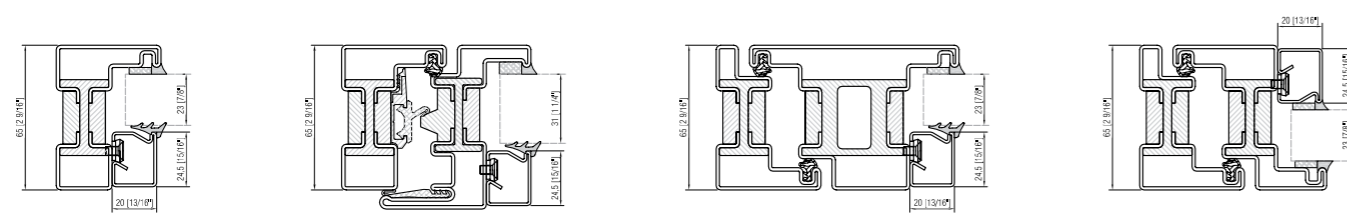

# metal

 available in GALVANIZED STEEL - CORTEN STEEL - STAINLESS STEEL - BRASS

P.2629 - CUSTOM sloped glazing bead



FIXED FRAME interior glazing bead

WINDOW open in interior glazing bead

DOOR open out interior glazing bead

WINDOW open out exterior glazing bead

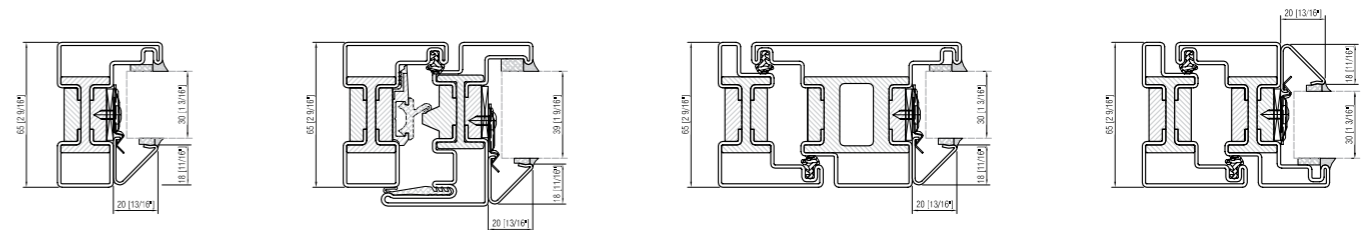

P.2028 gothic glazing bead



FIXED FRAME interior glazing bead

WINDOW open in interior glazing bead

DOOR open out interior glazing bead

WINDOW open out exterior glazing bead

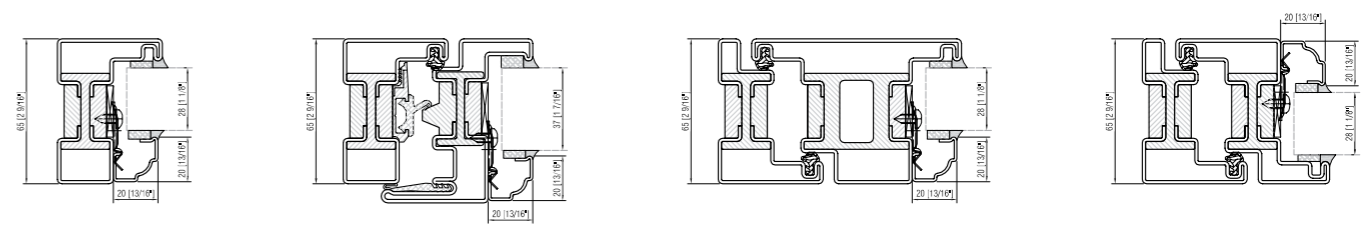

P.2038 L glazing bead



FIXED FRAME interior glazing bead

WINDOW open in interior glazing bead

DOOR open out interior glazing bead

WINDOW open out exterior glazing bead

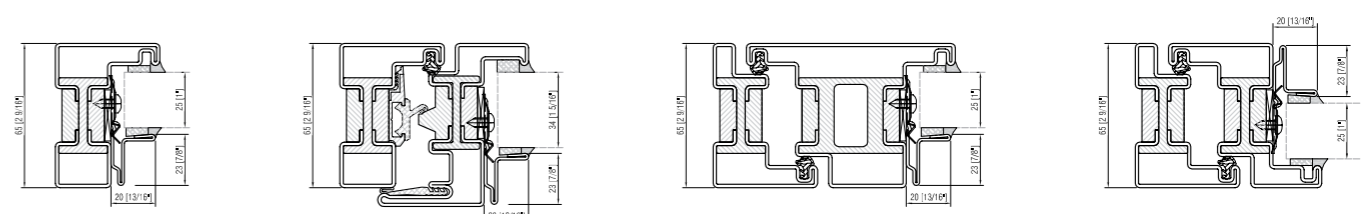



# metal

available in GALVANIZED STEEL - CORTEN STEEL - STAINLESS STEEL - BRASS

P.2015  
square glazing bead



FIXED FRAME interior glazing bead

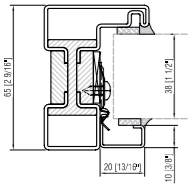

WINDOW open in interior glazing bead

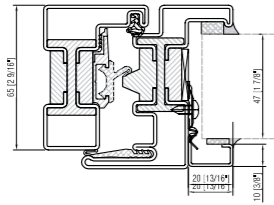

DOOR open out interior glazing bead

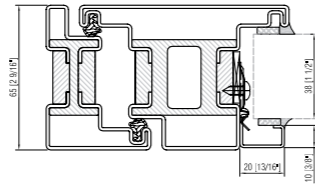

WINDOW open out exterior glazing bead

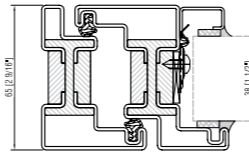

# aluminum

available for GALVANIZED STEEL POWDER COATED

PA.2038  
L glazing bead



FIXED FRAME interior glazing bead

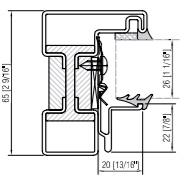

WINDOW open in interior glazing bead

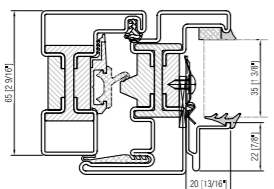

DOOR open out interior glazing bead

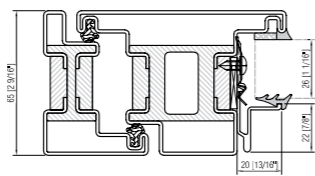

WINDOW open out exterior glazing bead

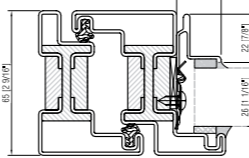

PA.2029  
sloped glazing bead



FIXED FRAME interior glazing bead

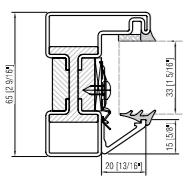

WINDOW open in interior glazing bead

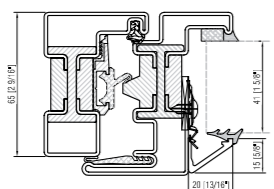

DOOR open out interior glazing bead

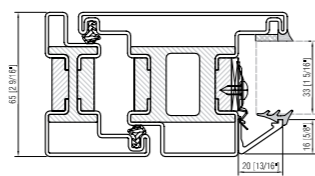

WINDOW open out exterior glazing bead

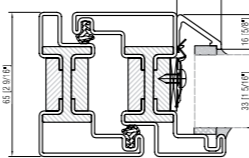

# metal

available in GALVANIZED STEEL - CORTEN STEEL - STAINLESS STEEL - BRASS

FLAT SDL AVAILABLE FOR:



STANDARD FLAT SDL

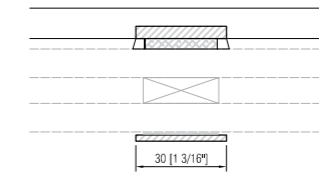

THINNER FLAT SDL

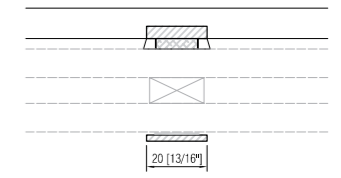

SLOPED SDL AVAILABLE FOR:



STANDARD STEEL SLOPED SDL

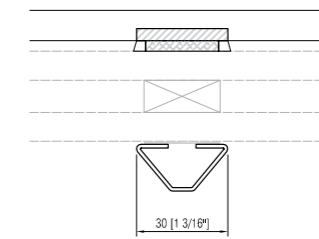

THINNER STEEL SLOPED SDL

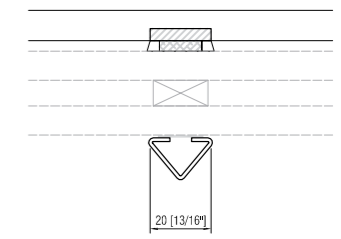

GOTHIC SDL AVAILABLE FOR:



STANDARD "GOTHIC" SDL

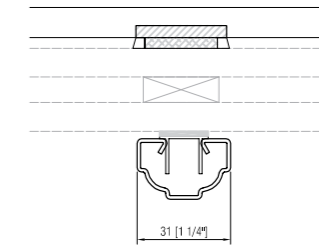

STANDARD SQUARE SDL AVAILABLE FOR:



STANDARD SQUARE SDL

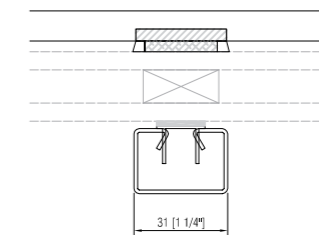

STANDARD SQUARE SDL

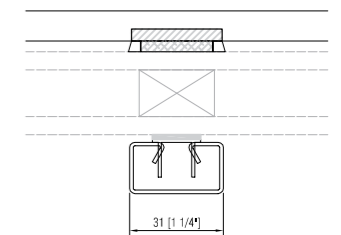

STANDARD TUBE SDL AVAILABLE FOR:



STANDARD TUBE SDL

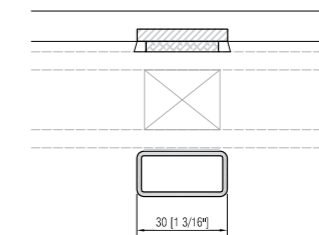

# aluminum

available for GALVANIZED STEEL POWDER COATED

STANDARD SLOPED SDL AVAILABLE FOR:



STANDARD SLOPED SDL

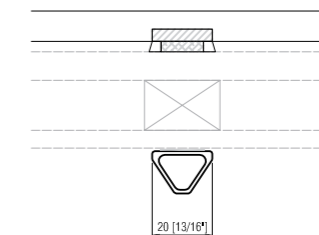

# EBE 73

- 1 glazing bead
- 2 maximum glazing pocket of 46mm (1 13/16")
- 3 fitting groove for hardware
- 4 flush on the exterior and interior
- 5 frame with weep system and triple gasket
- 6 structural thermal break in polyamide and polyurethane

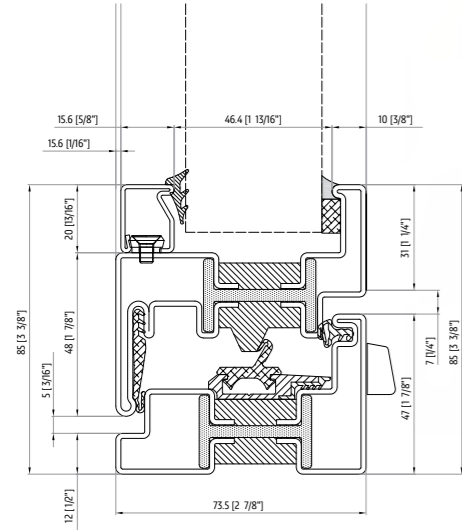

## profiles

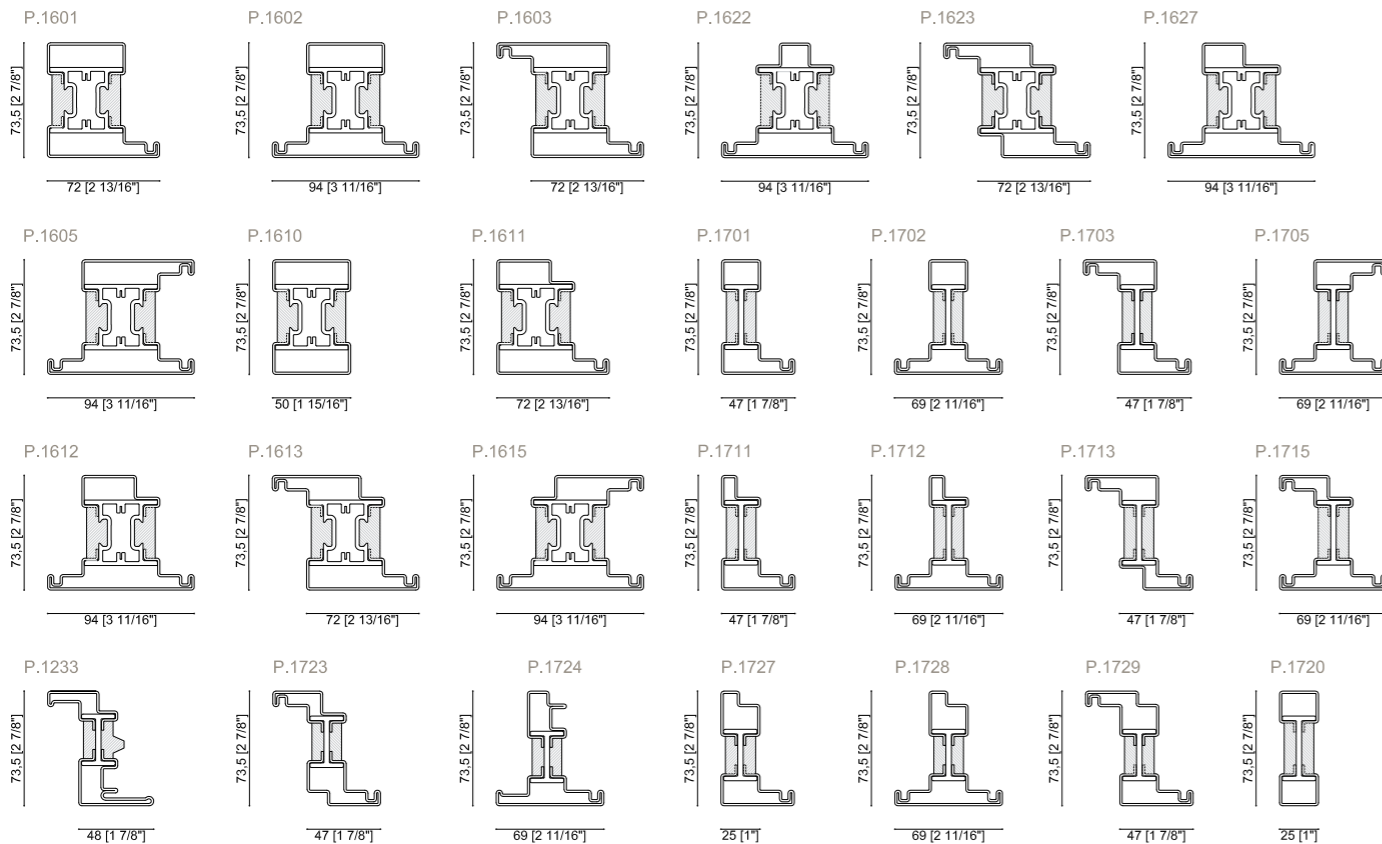

# EBE 73 configurations

Fixed window



Single casement, French casement, Awning, Hopper, Pivot

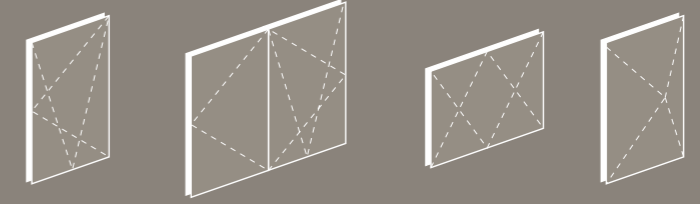

Hinged Doors including single and French Pivot Doors

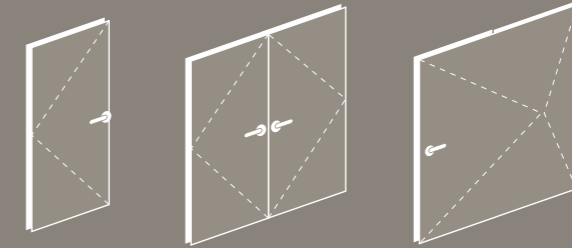

Bi-fold Doors Lift and slide Doors

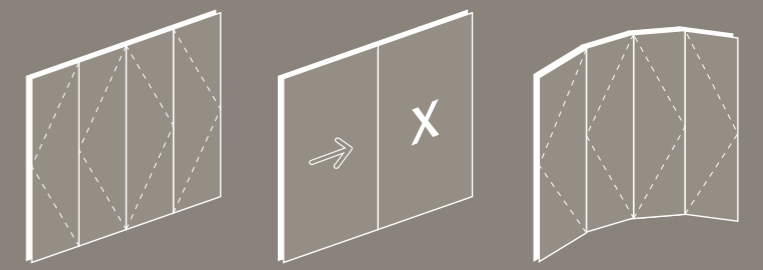

Arched top, Shaped and Curved units

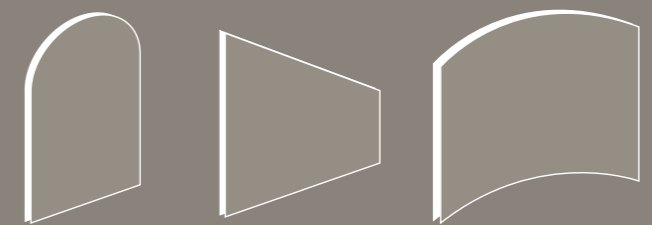

Composite units and Corner configurations for unobstructed views

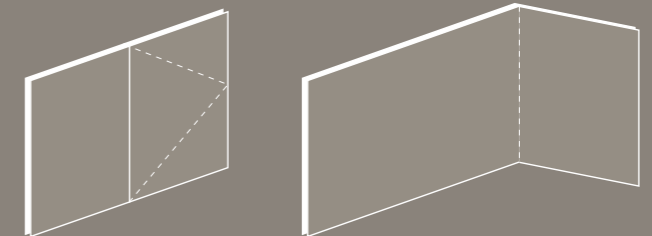

metal available in GALVANIZED STEEL - CORTEN STEEL - STAINLESS STEEL - BRASS

P.1007 square glazing bead



- FIXED FRAME interior glazing bead
- WINDOW open in interior glazing bead
- DOOR open out interior glazing bead
- WINDOW open out exterior glazing bead

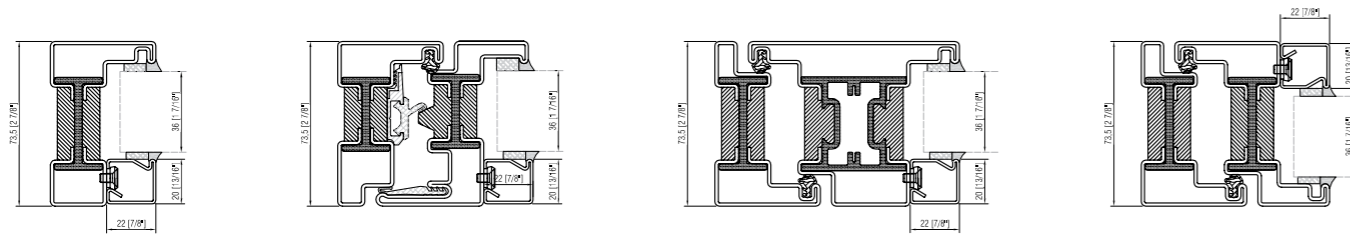

P.2007 square glazing bead



- FIXED FRAME interior glazing bead
- WINDOW open in interior glazing bead
- DOOR open out interior glazing bead
- WINDOW open out exterior glazing bead

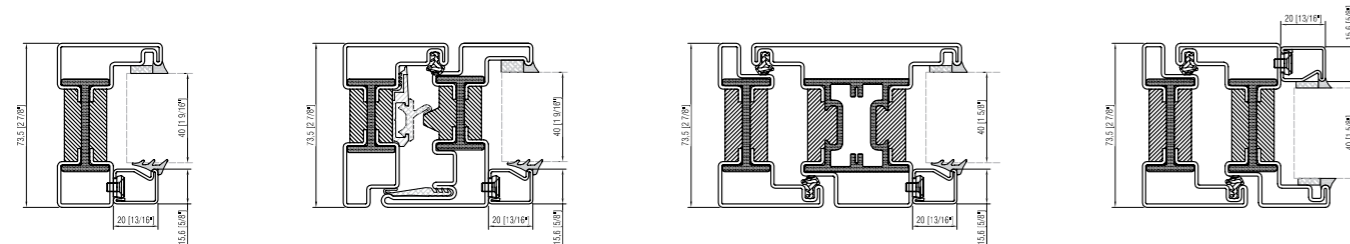

P.2008 square glazing bead



- FIXED FRAME interior glazing bead
- WINDOW open in interior glazing bead
- DOOR open out interior glazing bead
- WINDOW open out exterior glazing bead

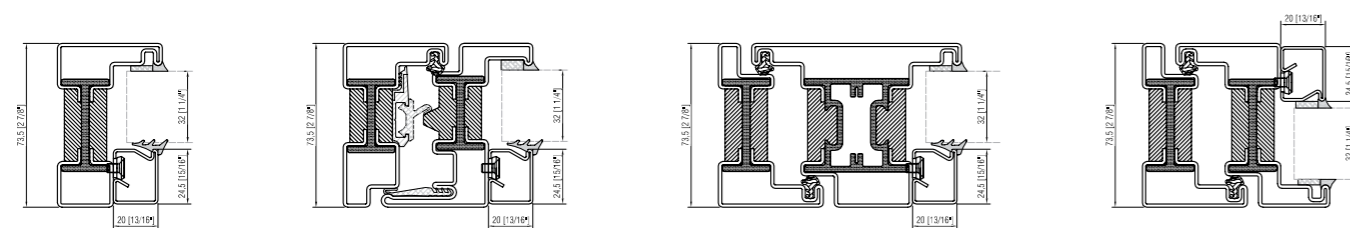

metal available in GALVANIZED STEEL - CORTEN STEEL - STAINLESS STEEL - BRASS

P.2629 - CUSTOM sloped glazing bead



- FIXED FRAME interior glazing bead
- WINDOW open in interior glazing bead
- DOOR open out interior glazing bead
- WINDOW open out exterior glazing bead

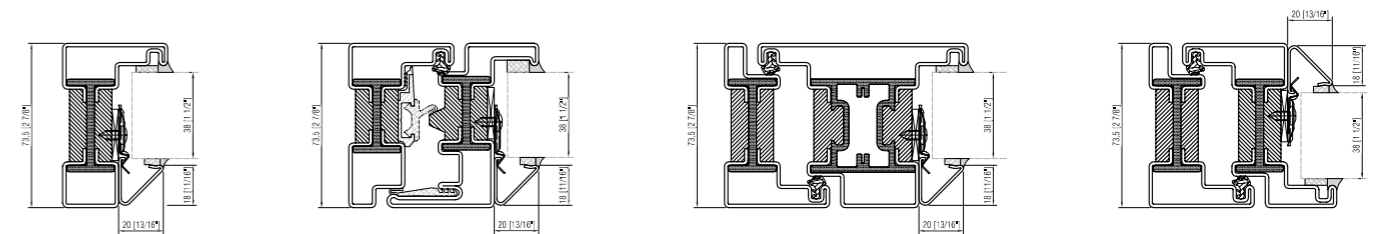

P.2028 gothic glazing bead



- FIXED FRAME interior glazing bead
- WINDOW open in interior glazing bead
- DOOR open out interior glazing bead
- WINDOW open out exterior glazing bead

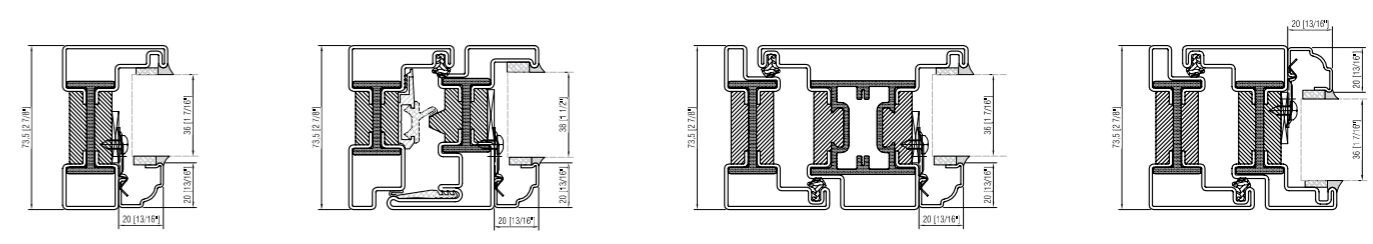

P.2038 L glazing bead



- FIXED FRAME interior glazing bead
- WINDOW open in interior glazing bead
- DOOR open out interior glazing bead
- WINDOW open out exterior glazing bead

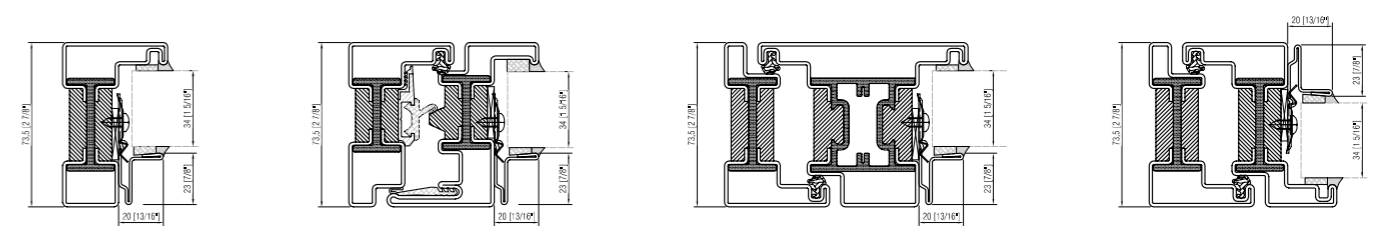

# metal

available in GALVANIZED STEEL - CORTEN STEEL - STAINLESS STEEL - BRASS

P.2015  
square glazing bead



FIXED FRAME interior glazing bead

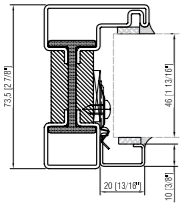

WINDOW open in interior glazing bead

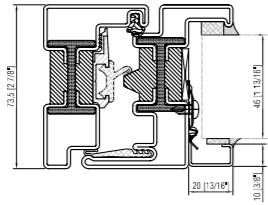

DOOR open out interior glazing bead

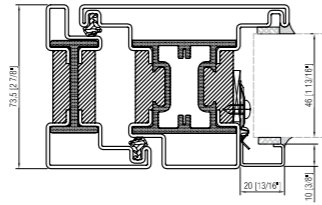

WINDOW open out exterior glazing bead

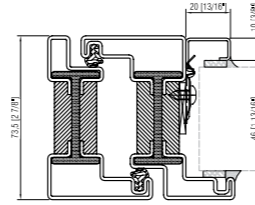

# aluminum

available for GALVANIZED STEEL POWDER COATED

PA.2038  
L glazing bead



FIXED FRAME interior glazing bead

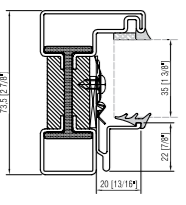

WINDOW open in interior glazing bead

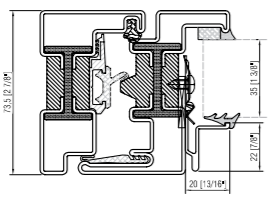

DOOR open out interior glazing bead

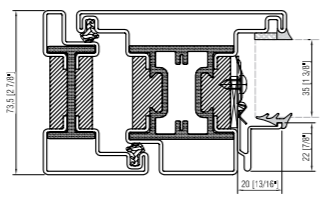

WINDOW open out exterior glazing bead

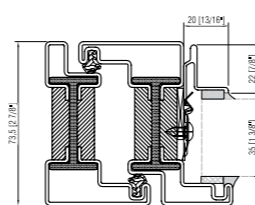

PA.2029  
sloped glazing bead



FIXED FRAME interior glazing bead

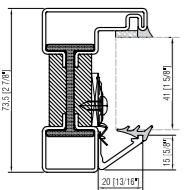

WINDOW open in interior glazing bead

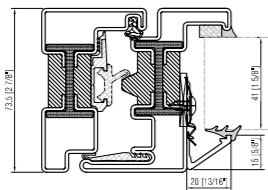

DOOR open out interior glazing bead

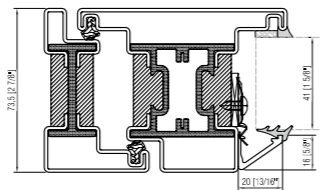

WINDOW open out exterior glazing bead

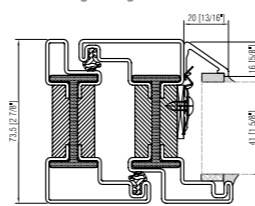

# metal

available in GALVANIZED STEEL - CORTEN STEEL - STAINLESS STEEL - BRASS

FLAT SDL AVAILABLE FOR:



STANDARD FLAT SDL

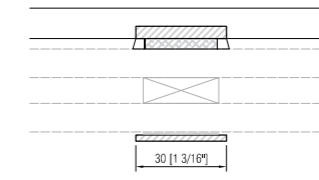

THINNER FLAT SDL

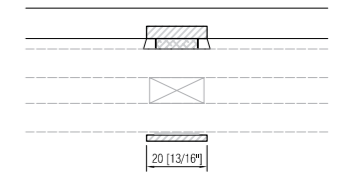

SLOPED SDL AVAILABLE FOR:



STANDARD STEEL SLOPED SDL

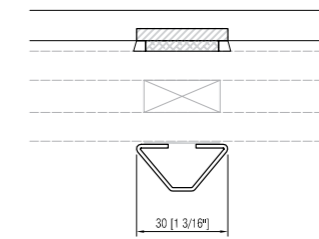

THINNER STEEL SLOPED SDL

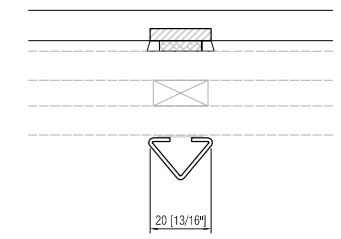

GOTHIC SDL AVAILABLE FOR:



STANDARD "GOTHIC" SDL

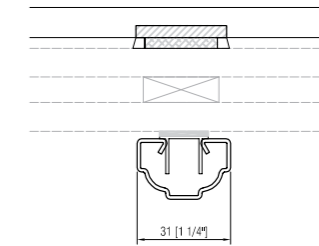

STANDARD SQUARE SDL AVAILABLE FOR:



STANDARD SQUARE SDL

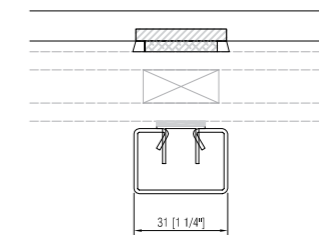

STANDARD SQUARE SDL

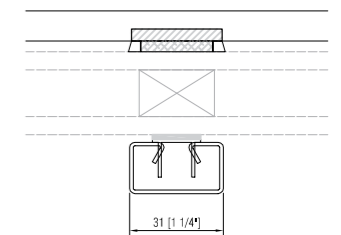

STANDARD TUBE SDL AVAILABLE FOR:



STANDARD TUBE SDL

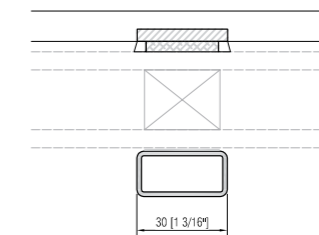

# aluminum

available for GALVANIZED STEEL POWDER COATED

STANDARD SLOPED SDL AVAILABLE FOR:



STANDARD SLOPED SDL

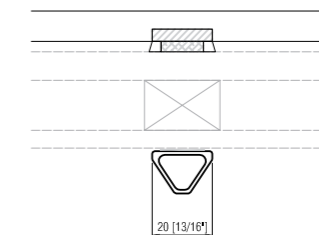

# EBE 85

- 1 glazing bead
- 2 maximum glazing pocket of 67mm (2 5/8")
- 3 fitting groove for hardware
- 4 flush on the exterior and rebated on the interior
- 5 frame with weep system and triple gasket
- 6 structural thermal break in polyamide and polyurethane

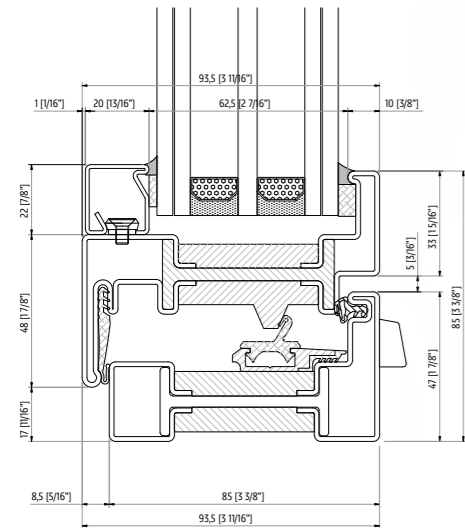

## profiles

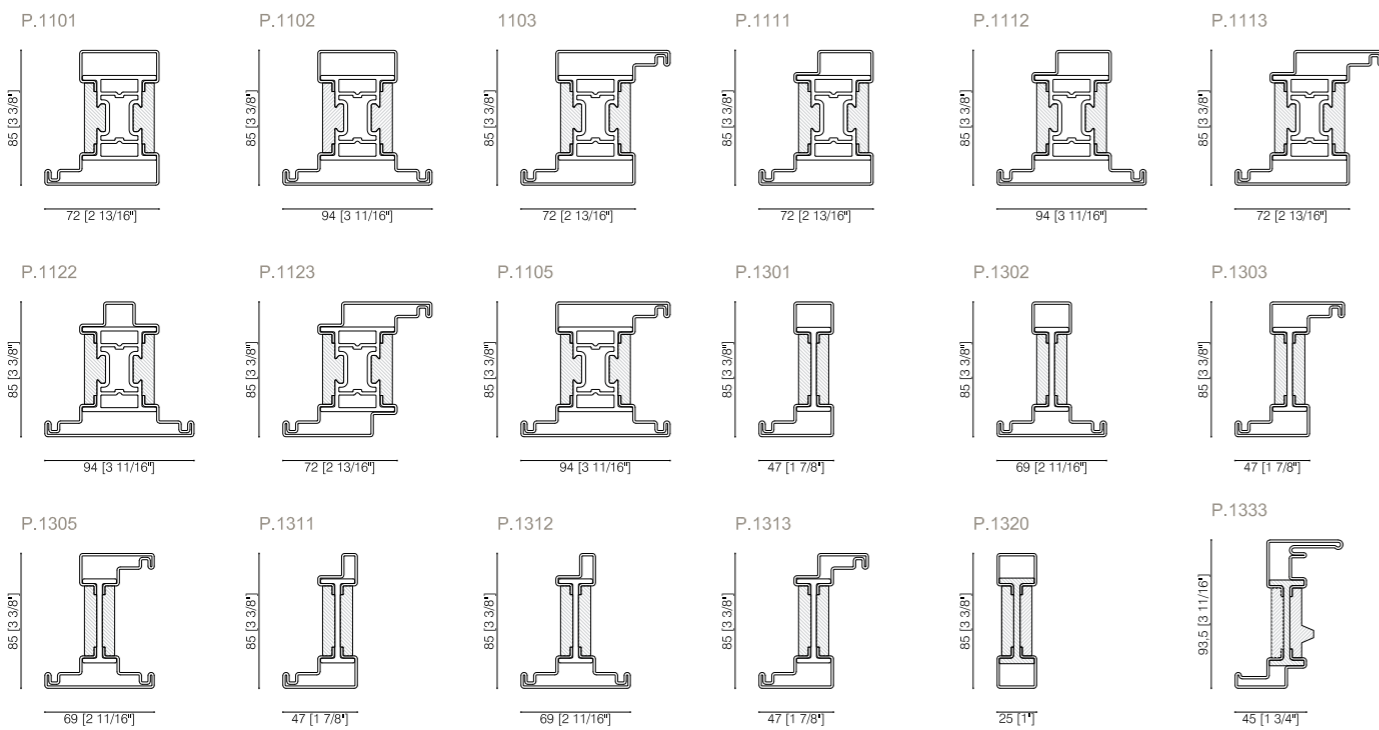

## EBE 85 configurations

Fixed window



Single casement, French casement, Awning, Hopper, Pivot

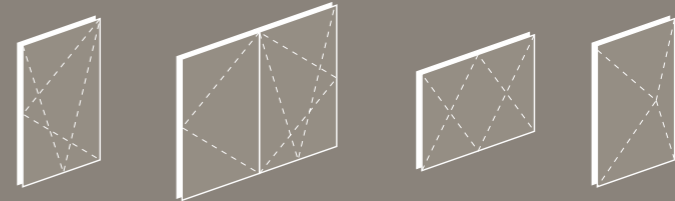

Hinged Doors including single and French Pivot Doors

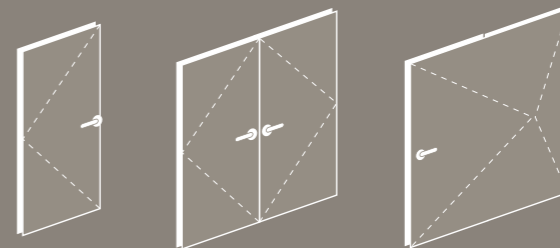

Bi-fold Doors Lift and slide Doors

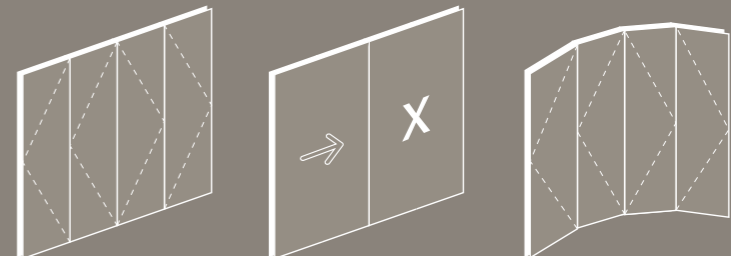

Arched top, Shaped and Curved units

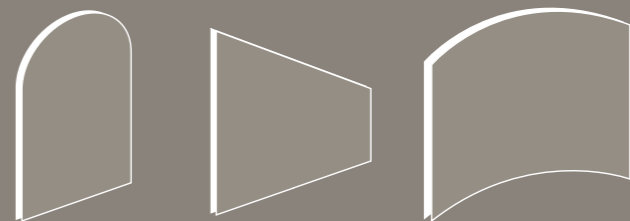

Composite units and Corner configurations for unobstructed views

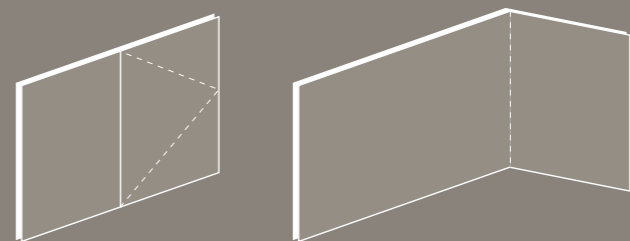

# metal

 available in GALVANIZED STEEL - CORTEN STEEL - STAINLESS STEEL - BRASS

P.1007 square glazing bead



FIXED FRAME interior glazing bead

WINDOW open in interior glazing bead

DOOR open out interior glazing bead

WINDOW open out exterior glazing bead

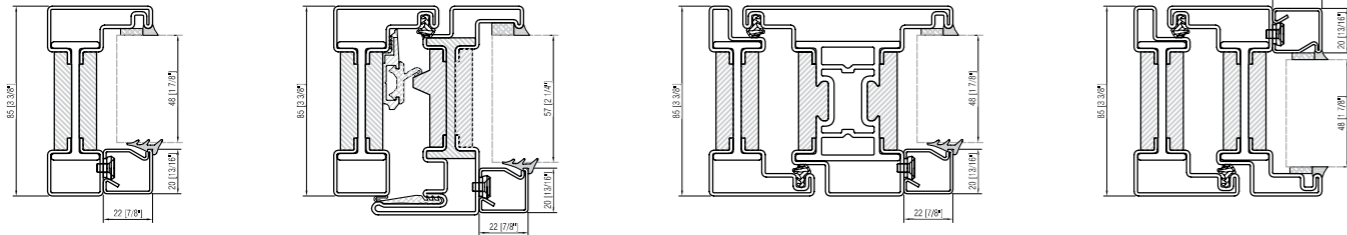

P.2007 square glazing bead



FIXED FRAME interior glazing bead

WINDOW open in interior glazing bead

DOOR open out interior glazing bead

WINDOW open out exterior glazing bead

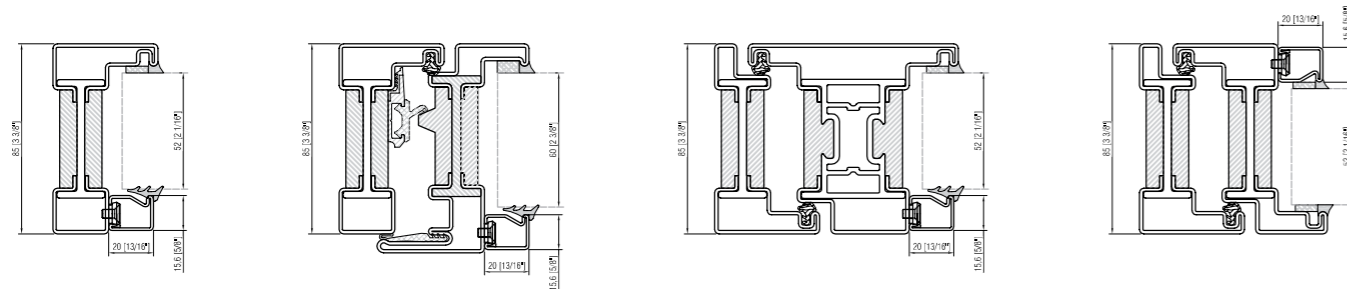

P.2008 square glazing bead



FIXED FRAME interior glazing bead

WINDOW open in interior glazing bead

DOOR open out interior glazing bead

WINDOW open out exterior glazing bead

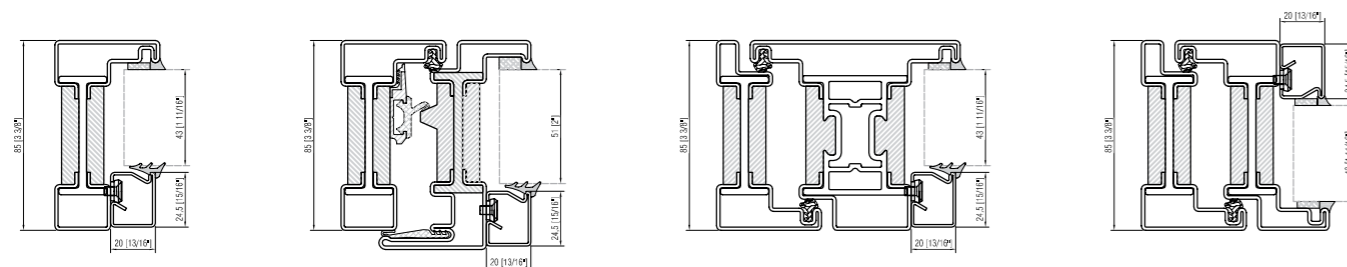

# metal

 available in GALVANIZED STEEL - CORTEN STEEL - STAINLESS STEEL - BRASS

P.2629 - CUSTOM sloped glazing bead



FIXED FRAME interior glazing bead

WINDOW open in interior glazing bead

DOOR open out interior glazing bead

WINDOW open out exterior glazing bead

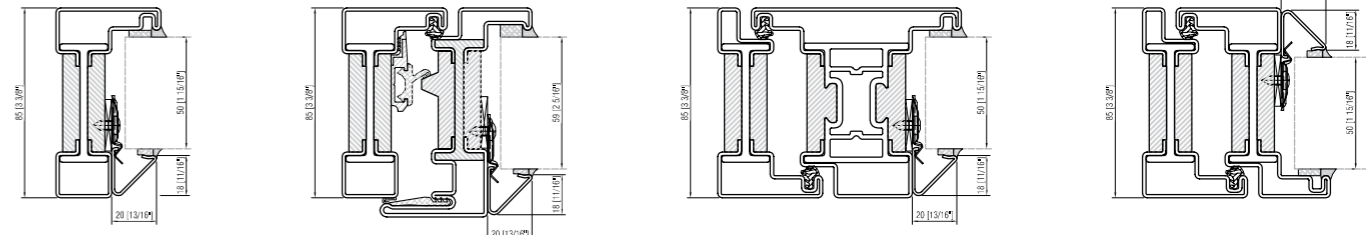

P.2028 gothic glazing bead



FIXED FRAME interior glazing bead

WINDOW open in interior glazing bead

DOOR open out interior glazing bead

WINDOW open out exterior glazing bead

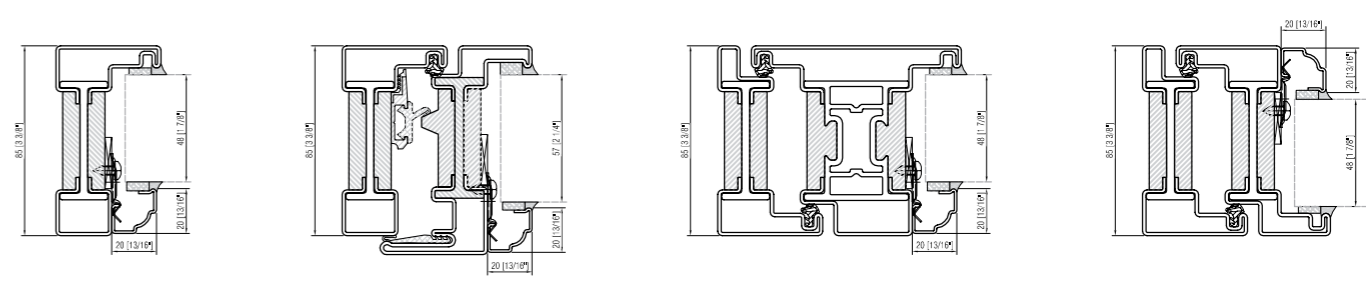

P.2038 L glazing bead



FIXED FRAME interior glazing bead

WINDOW open in interior glazing bead

DOOR open out interior glazing bead

WINDOW open out exterior glazing bead

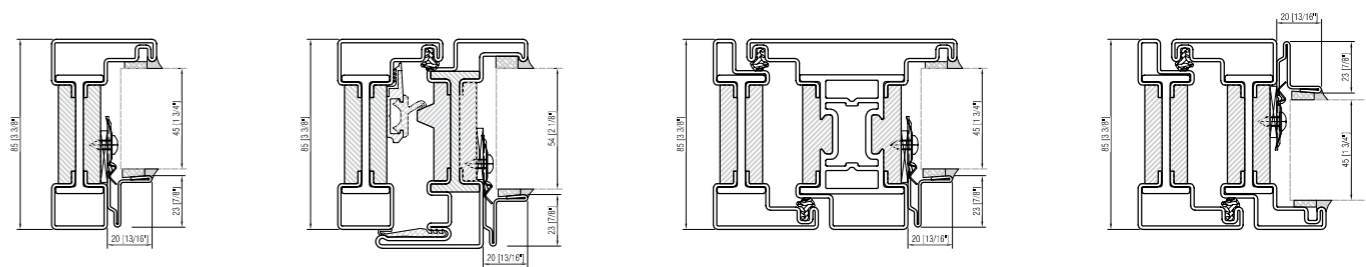

# metal

available in GALVANIZED STEEL - CORTEN STEEL - STAINLESS STEEL - BRASS

P.2015  
square glazing bead



FIXED FRAME interior glazing bead

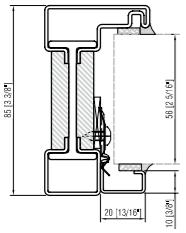

WINDOW open in interior glazing bead

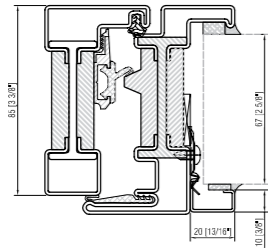

DOOR open out interior glazing bead

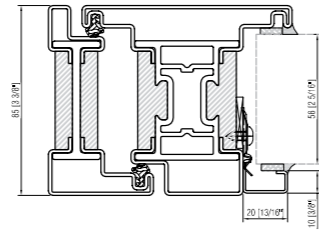

WINDOW open out exterior glazing bead

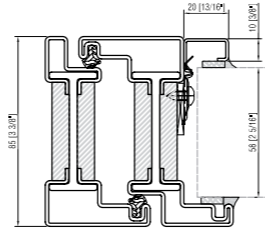

# aluminum

available for GALVANIZED STEEL POWDER COATED

PA.2038  
L glazing bead



FIXED FRAME interior glazing bead

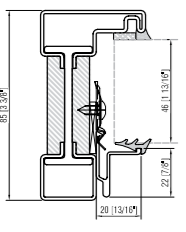

WINDOW open in interior glazing bead

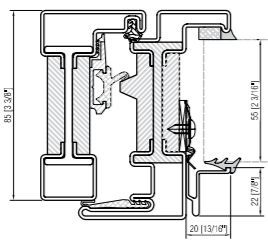

DOOR open out interior glazing bead

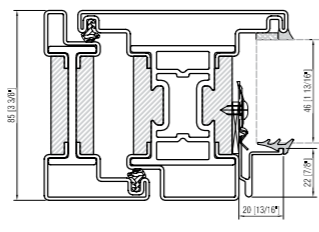

WINDOW open out exterior glazing bead

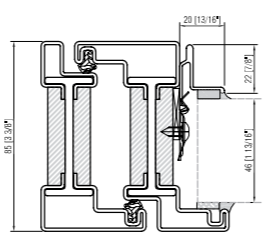

PA.2029  
sloped glazing bead



FIXED FRAME interior glazing bead

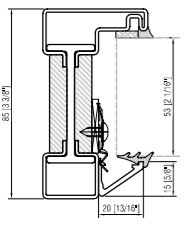

WINDOW open in interior glazing bead

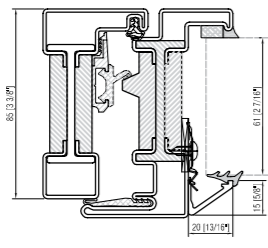

DOOR open out interior glazing bead

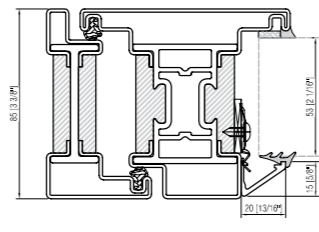

WINDOW open out exterior glazing bead

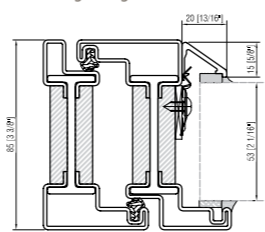

# metal

available in GALVANIZED STEEL - CORTEN STEEL - STAINLESS STEEL - BRASS

FLAT SDL AVAILABLE FOR:



STANDARD FLAT SDL

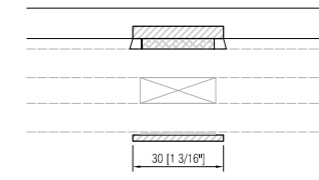

THINNER FLAT SDL

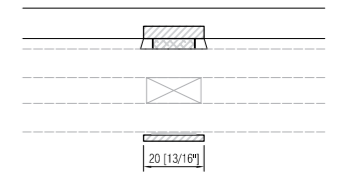

SLOPED SDL AVAILABLE FOR:



STANDARD STEEL SLOPED SDL

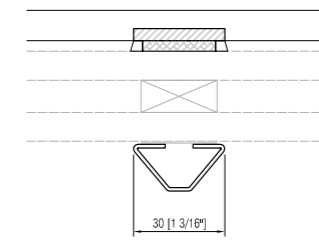

THINNER STEEL SLOPED SDL

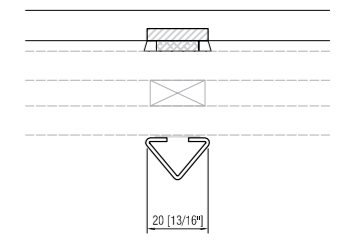

GOTHIC SDL AVAILABLE FOR:



STANDARD "GOTHIC" SDL

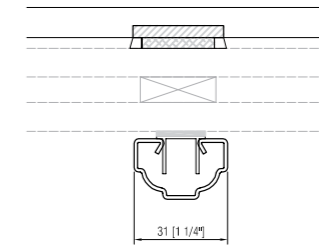

STANDARD SQUARE SDL AVAILABLE FOR:



STANDARD SQUARE SDL

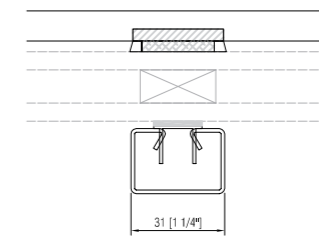

STANDARD SQUARE SDL

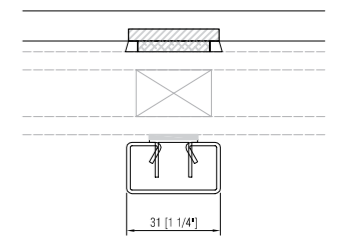

STANDARD TUBE SDL AVAILABLE FOR:



STANDARD TUBE SDL

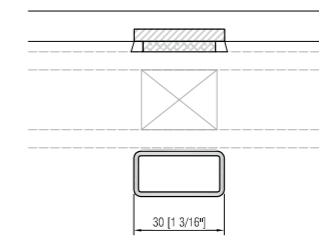

# aluminum

available for GALVANIZED STEEL POWDER COATED

STANDARD SLOPED SDL AVAILABLE FOR:



STANDARD SLOPED SDL

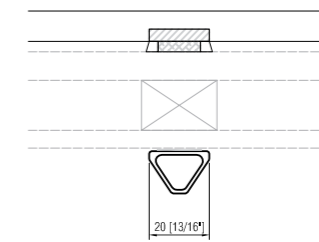

# EBE STYLE

available in brass only

- 1 glazing bead
- 2 maximum glazing pocket of 32mm (1 1/4")
- 3 fitting groove for hardware
- 4 flush on the exterior and rebated on the interior
- 5 frame with weep system and triple gasket
- 6 structural thermal break in polyamide and polyurethane

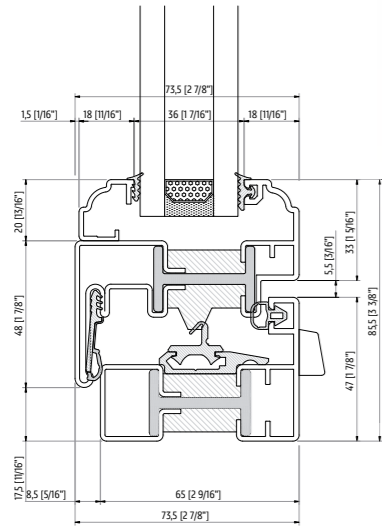

## profiles

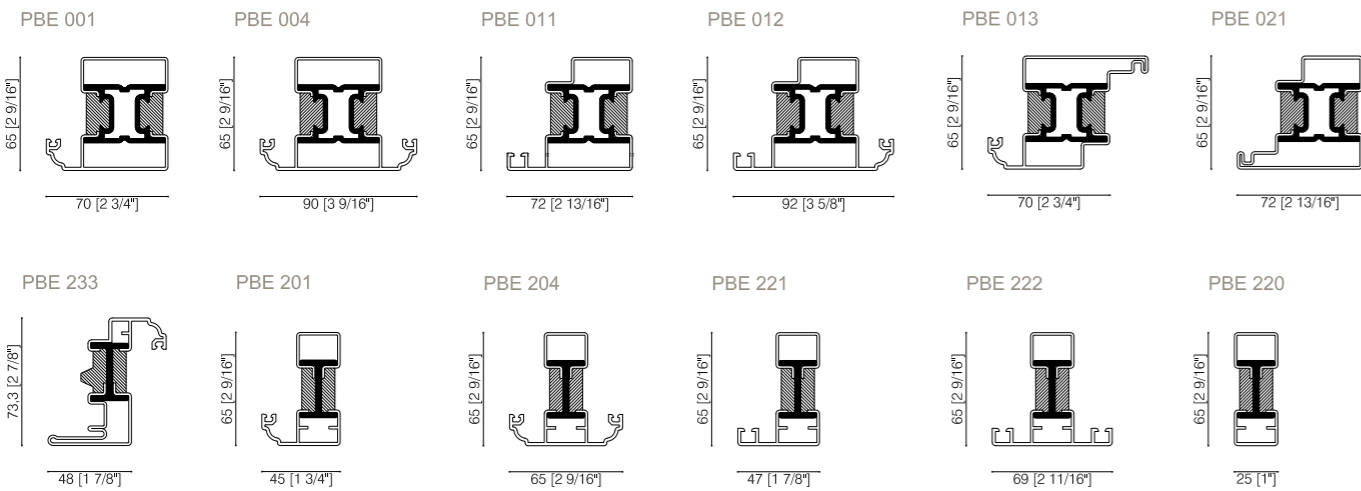

## glazing bead

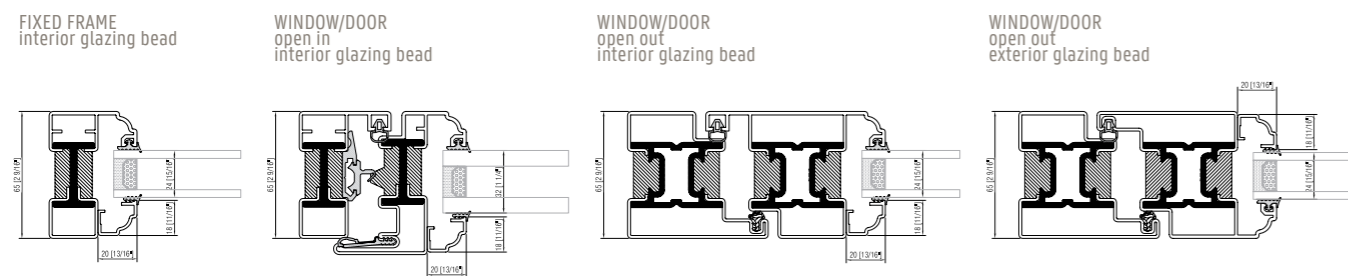

# EBE STYLE configurations

Fixed window



Single casement, French casement, Awning, Hopper, Pivot

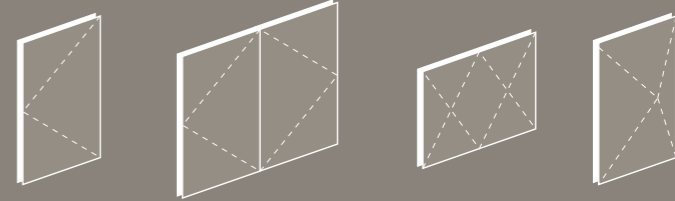

Hinged Doors including single and French Pivot Doors

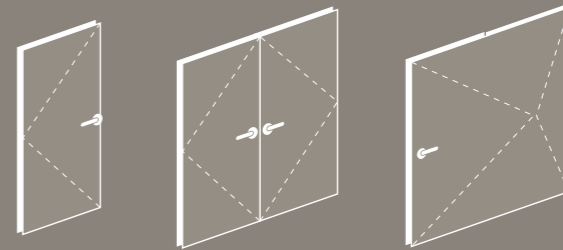

Arched top, Shaped and Curved units

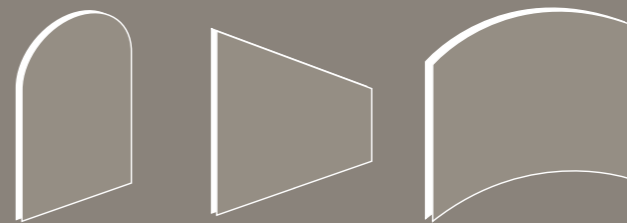

Composite units and Corner configurations for unobstructed views

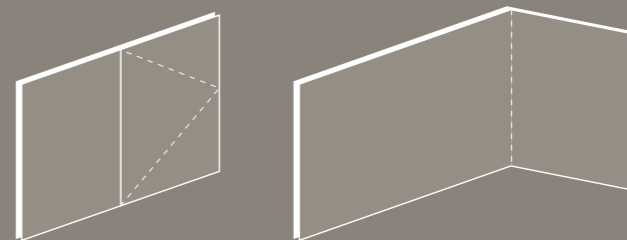



# EBE METAL WOOD

- 1 internal solid wood cladding
- 2 maximum glazing pocket of 51mm (2")
- 3 fitting groove for hardware
- 4 flush on the exterior and rebated on the interior
- 5 frame with weep system and triple gasket
- 6 structural thermal break in polyamide and polyurethane

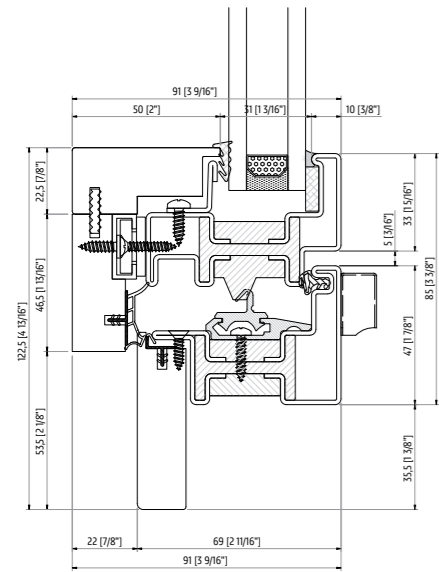

## profiles

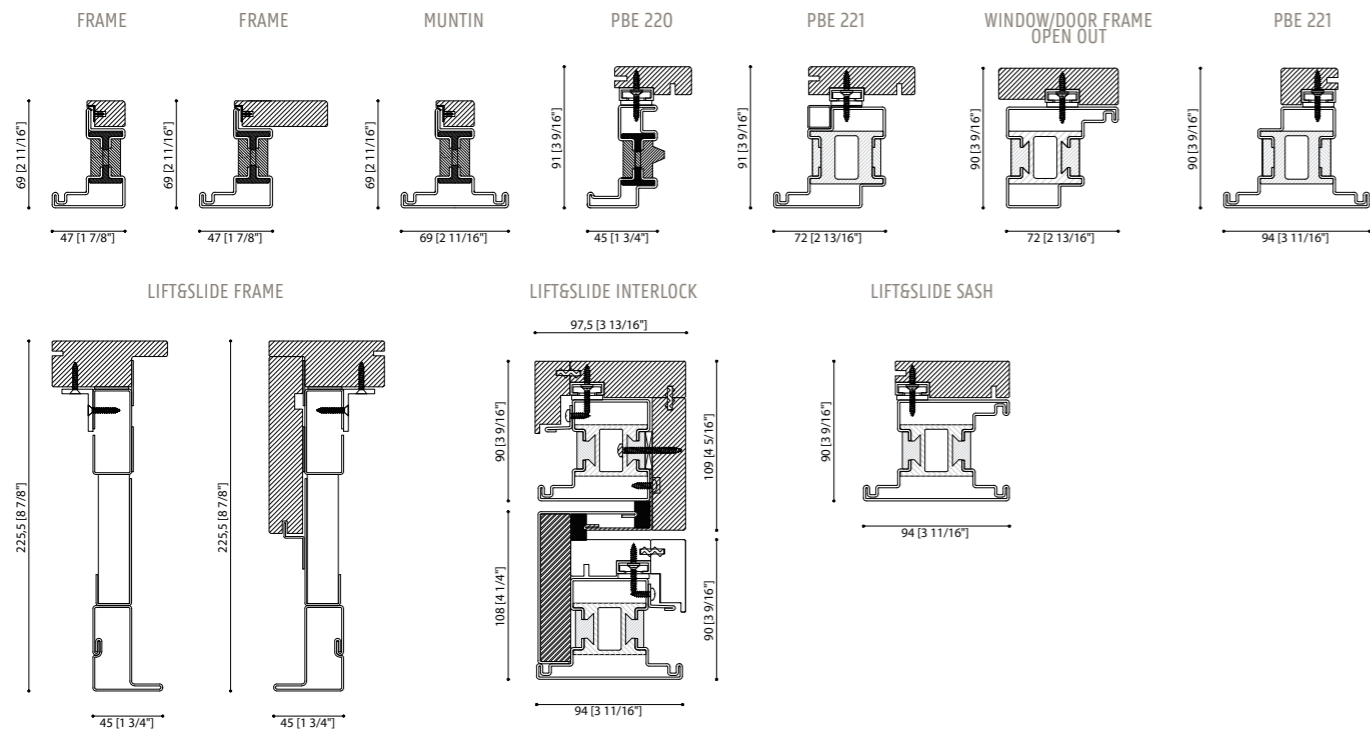

## EBE METAL WOOD configurations

Fixed window



Single casement, French casement, Awning, Hopper, Pivot

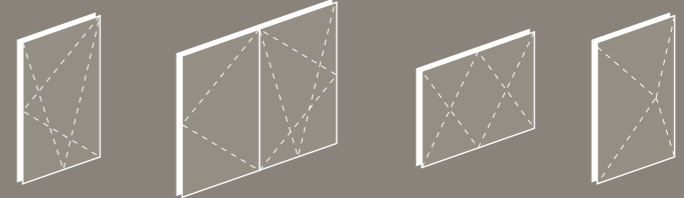

Hinged Doors including single and French Pivot Doors

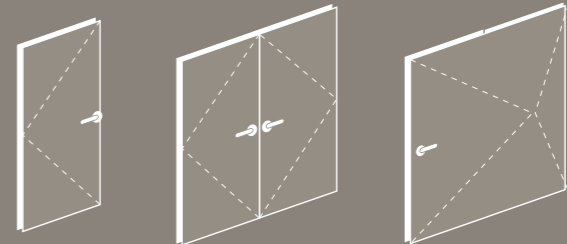

Bi-fold Doors Lift and slide Doors

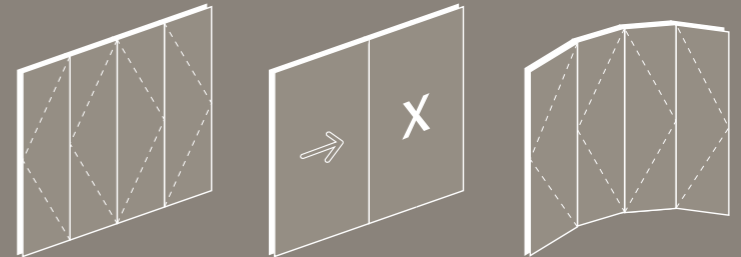

Arched top, Shaped and Curved units

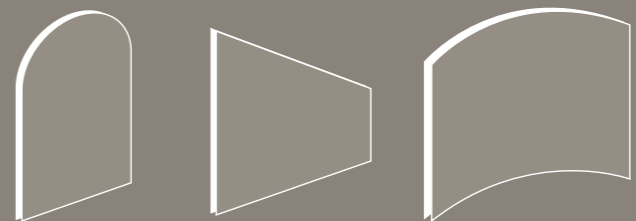

Composite units and Corner configurations for unobstructed views

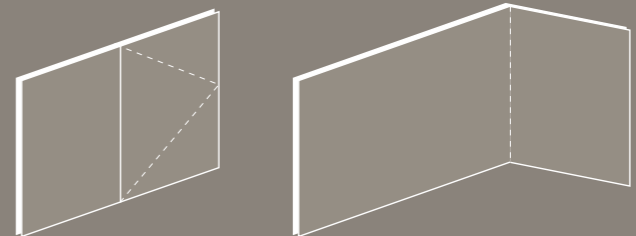



# CURTAIN WALL

4F1  
4F2



The synergy between industrial technology and craftsmanship ensures living comfort and superior performance.

The steel curtain wall by our profile system guarantees full compatibility and integration with the architectural design. This solution combines slim profiles, large glass surfaces and a wide range of openings in an integrated door-window facade system that features structural performance levels three times higher than aluminum and excellent resistance. In order to meet the current technical and technological needs of the building envelope, our profile system leads the entire product design and manufacturing process to offer a complete and rigorous certification based on the transparency of data, thanks to the expertise acquired in the development of galvanized steel, stainless steel, Corten steel and brass windows and doors.

# 4F1

- 1 mullion/transom profiles in 5 finishes
- 2 maximum glazing pocket of 56mm (2 3/16")
- 3 sealing and water draining gaskets system
- 4 extruded polyethylene foam for greater technical performance
- 5 pre-drilled hold-down device for easy installation
- 6 cover profile in 7 finishes

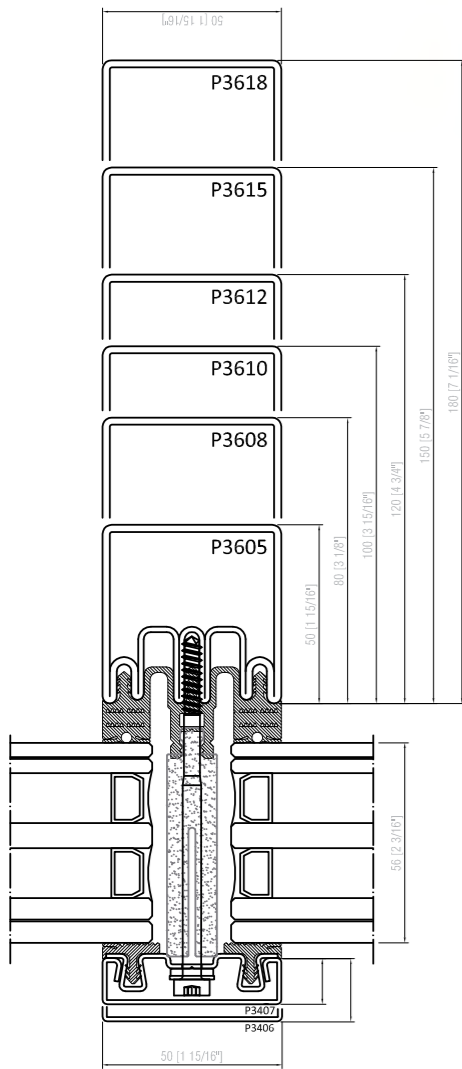
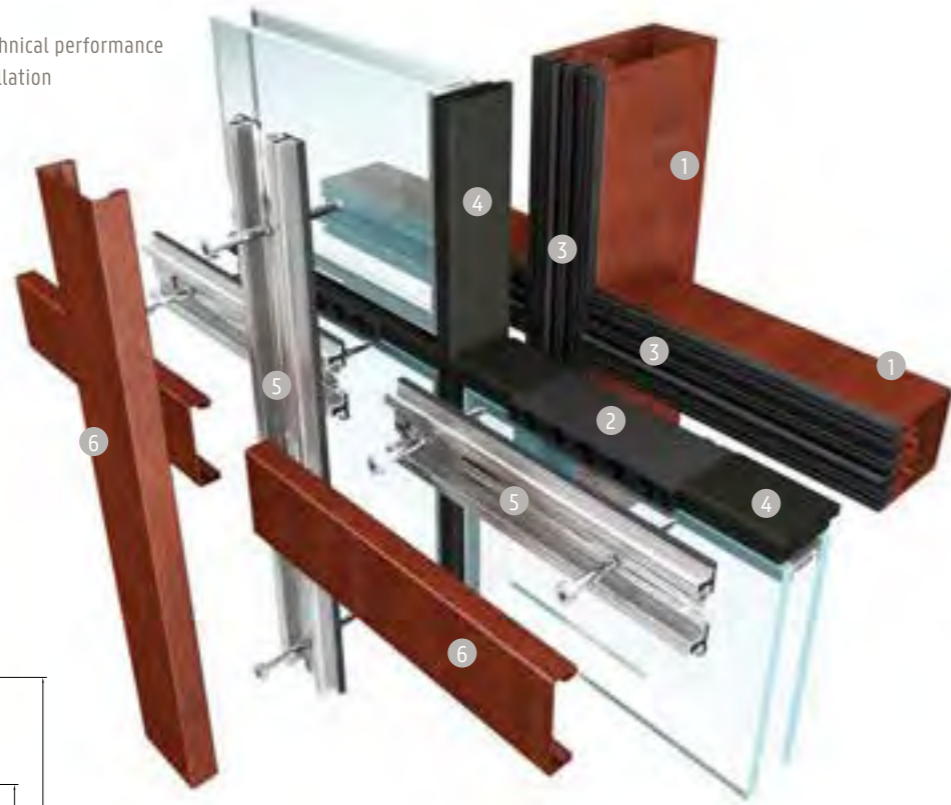

profiles

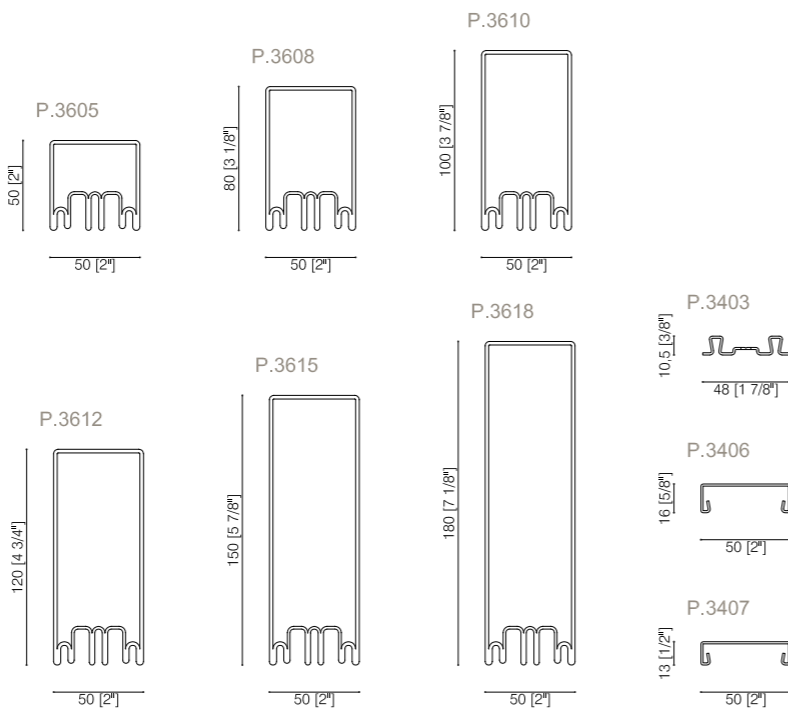

# 4F1 materials available

material for transom and mullions



galvanized steel



stainless steel



corten steel

material for covers



galvanized steel



stainless steel

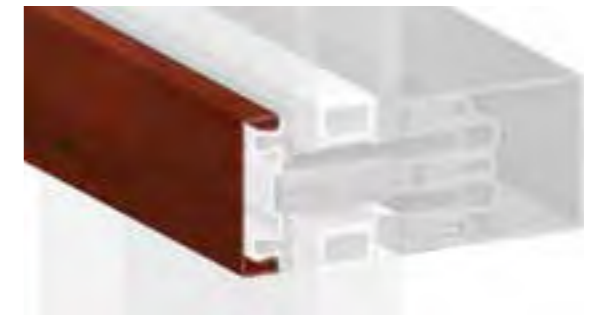

corten steel



brass

# 4F2

- 1 mullion/transom profiles in 5 finishes
- 2 maximum glazing pocket of 56mm (2 3/16")
- 3 sealing and water draining gaskets system
- 4 extruded polyethylene foam for greater technical performance
- 5 pre-drilled hold-down device for easy installation
- 6 cover profile in 7 finishes

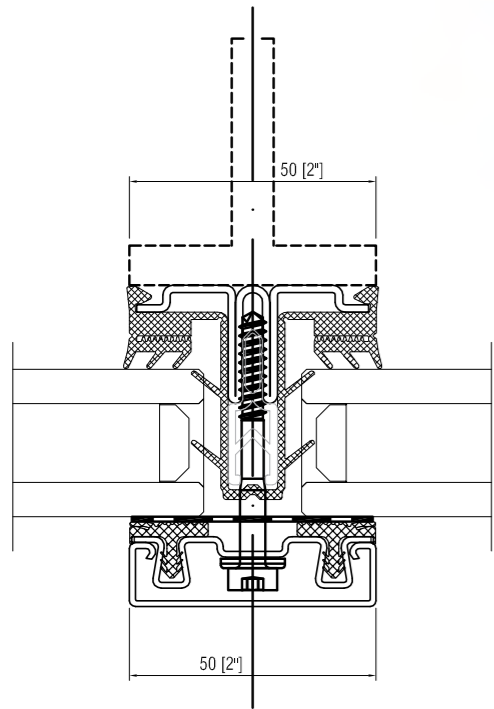

profiles

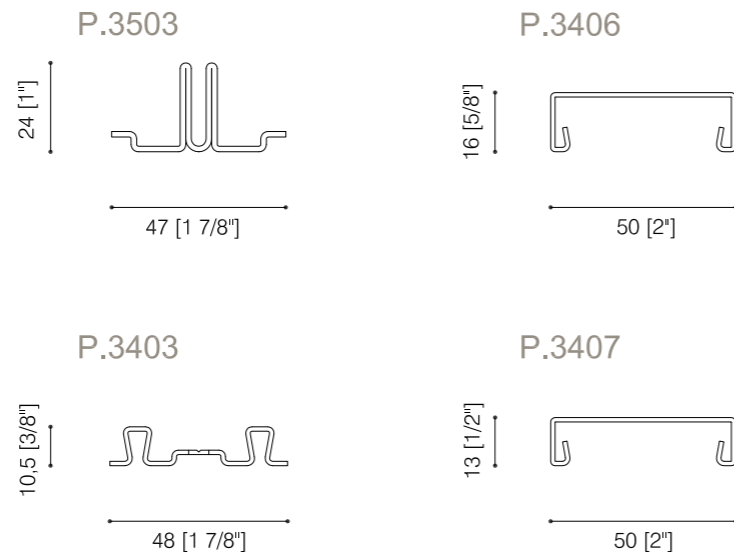

## 4F2 materials available and application options

### material for covers



galvanized steel



stainless steel



corten steel



brass

### application options



IPE welded beam



rectangular pipe



customized welded girder



wooden girder

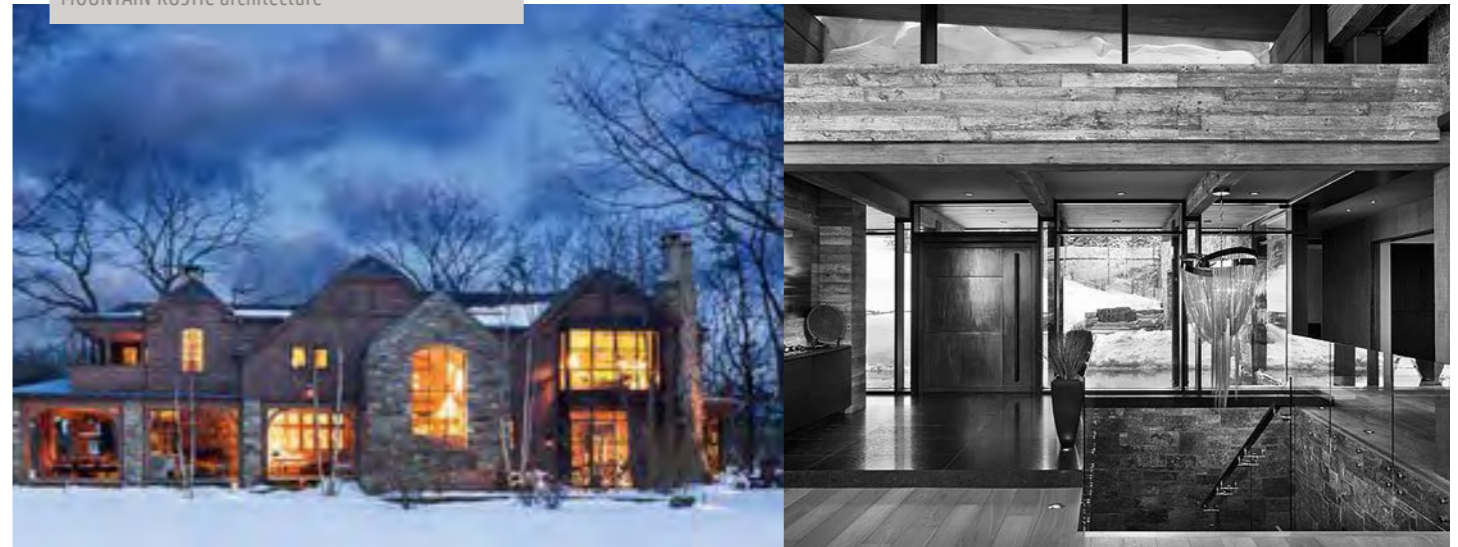



Discover freedom to create.

**EUROPE**

[www.brombal.it](http://www.brombal.it)  
[info@brombal.it](mailto:info@brombal.it)  
+39 0423 566189

**NORTH AMERICA**

[www.brombalusa.com](http://www.brombalusa.com)  
[sales@brombalusa.com](mailto:sales@brombalusa.com)  
+1 855 287 2258

**OCEANIA**

[www.brombaloceania.com](http://www.brombaloceania.com)  
[info@brombaloceania.com](mailto:info@brombaloceania.com)  
+64 21 661016



BROMBAL

